



===== CONTENTS =====

1	INTRODUCTION	3
2	FEATURES	3
2.1.	CPU.....	3
2.2.	LCD/PPU.....	3
3	PIN ASSIGNMENT	4
4	BLOCK DIAGRAM	5
5	FUNCTION DESCRIPTION	6
5.1.	ROM	6
5.2.	RAM	6
5.3.	INTERRUPT.....	7
5.4.	OPERATION MODE.....	7
5.5.	I/O PORTS	7
5.6.	WATCH DOG TIMER	7
5.7.	TIMER	8
5.8.	UART	8
5.9.	SERIAL PERIPHERAL INTERFACE (SPI)	8
5.10.	PWM IO CONTROL.....	8
5.11.	VOLTAGE DETECTOR	8
5.12.	AUTO SCAN KEY FUNCTION.....	9
5.13.	PICTURE PROCESSING UNIT (PPU).....	9
5.14.	SOUND PROCESSING UNIT (SPU)	10
5.14.1	<i>Sampling Rate Counters</i>	10
5.14.2	<i>Auto Repetition</i>	10
5.14.3	<i>Voice Synthesizer</i>	10
6	APPLICATION CIRCUIT	11
7	ABSOLUTE MAXIMUM RATING	14
8	ELECTRICAL CHARACTERISTICS	14
9	SYSTEM HIGH-CLOCK	15
10	VLCD POWER	16



AMENDMENT HISTORY

Version	Date	Description
Ver 1.0	Feb 17, 2009	First issue
Ver 1.1	Feb 17, 2009	Modify application circuit of auto scan key
Ver 1.2	Feb 27, 2009	Modify operating voltage range
Ver 1.3	May 15, 2009	Modify application circuit
Ver 1.4	June 29, 2009	1. Upgrade Maximum WPU channel to 16. 2. Add SPEC of input high voltage and input low voltage
Ver 1.5	July 02, 2009	Add new chapter to descript system high clock
Ver 1.6	July 27, 2009	1. Modify description of ROM Size 2. Add VLCD Power SPEC in the electrical characteristics chapter 3. Add chapter 10 to descript VLCD power

1 INTRODUCTION

The SNL261 is an 8-bit LCD controller embedded 2K dots with 4-grays LCD driver. It contains an 8-bit CPU core, Picture Processing Unit (PPU), Sound Processing Unit (SPU) and other primary functions for LCD games, Education Learning Aids (ELA).

The PPU can process all the graphic data and control the picture display of the system. The SPU is an 16-channel wave table music synthesizer compatible with standard MIDI stream format. It's low power consumption makes it ideal for all battery operated handheld LCD devices.

2 FEATURES

2.1. CPU

- ◆ Single Power Supply 2.4V – 5.1V
- ◆ System clock source can be select from 16M RC or 32768 X'tal.
- ◆ Dedicated 24 I/O pins
- ◆ Built-in an 8x8 multiplier
- ◆ RAM: 2304 Bytes * 8 bits (including LCD display RAM)
- ◆ ROM: 768K X 12 bits
- ◆ 4 Operating modes: Normal, Slow, Idle and Halt.
- ◆ Universal Asynchronous Receiver/Transmitter (UART), 1200 bps to 115.2kbps
- ◆ Serial Peripheral Interface (SPI) is provided
- ◆ SONiX SNAD01 ADC Interface.
- ◆ H/W 16x8 Matrix key scan Interface (Occupy 8 I/O and share with 16 COM signal)
- ◆ 4 H/W PWM I/Os with 256 levels duty control
- ◆ IR function is provided
- ◆ 16 CH Voice/MIDI synthesizer, compatible with General MIDI stream format
- ◆ Mark Event Supported in both Wave and Melody.
- ◆ Individual adaptive playing speed from 4k - 64kHz for all 16 voice channels.
- ◆ 10 Bit Direct Drive push pull type current DAC.
- ◆ Low Voltage Reset(LVR) is provided
 - Reset at 1.8V
- ◆ Voltage Detect (LVD) is provided
 - 2.4/2.6/2.8 V

2.2. LCD/PPU

- ◆ LCD resolution: 32x64, (maximum 2048 dots), 1/32 buty,1/6 bias
- ◆ Built-in Voltage booster and voltage regulator
- ◆ 32 levels Brightness Adjustment
- ◆ Support four grays color
- ◆ Object oriented design support 3 depth layers for all graphic objects.
- ◆ Graphic object support diverse size
- ◆ Support H/W scrolling function

3 PIN ASSIGNMENT

Symbol	I/O	Function Description
P00 ~ P07	I/O	Bit7 ~ Bit0 of I/O port 0
P50 ~ P57	I/O	Bit7 ~ Bit0 of I/O port 5
P60 ~ P67	I/O	Bit7 ~ Bit0 of I/O port 6
VDDVR	P	Positive power supply for low clock
GNDVR	P	Negative power supply for low clock
VDDPP	P	Positive power supply for Audio
GNDPP	P	Negative power supply for Audio
VDDCP	P	Positive power supply for LCD Driver
GNDCP	P	Negative power supply for LCD driver
VDD	P	Positive power supply for I/O
GND	P	Negative power supply
RegOut	P	3V regulator output
CVDD	P	Positive power supply for CPU Core
RST	I	Chip Reset (Active low)
LXIN	I	Low clock Crystal Input
LXOUT	O	Low clock Crystal Out
TESTM1~2	I	Test Pin
BN0	O	Direct Drive negative output
BP0	O	Direct Drive positive output
V1~V4	P	LCD voltage generation
C1N,C1P	P	Charge pump cap
C2N,C2P	P	Charge pump cap
VLCD	P	LCD voltage generation
COM0~COM31	O	LCD COM0~COM31 output
SEG0~SEG63	O	LCD SEG0~SEG63 output

4 Block Diagram

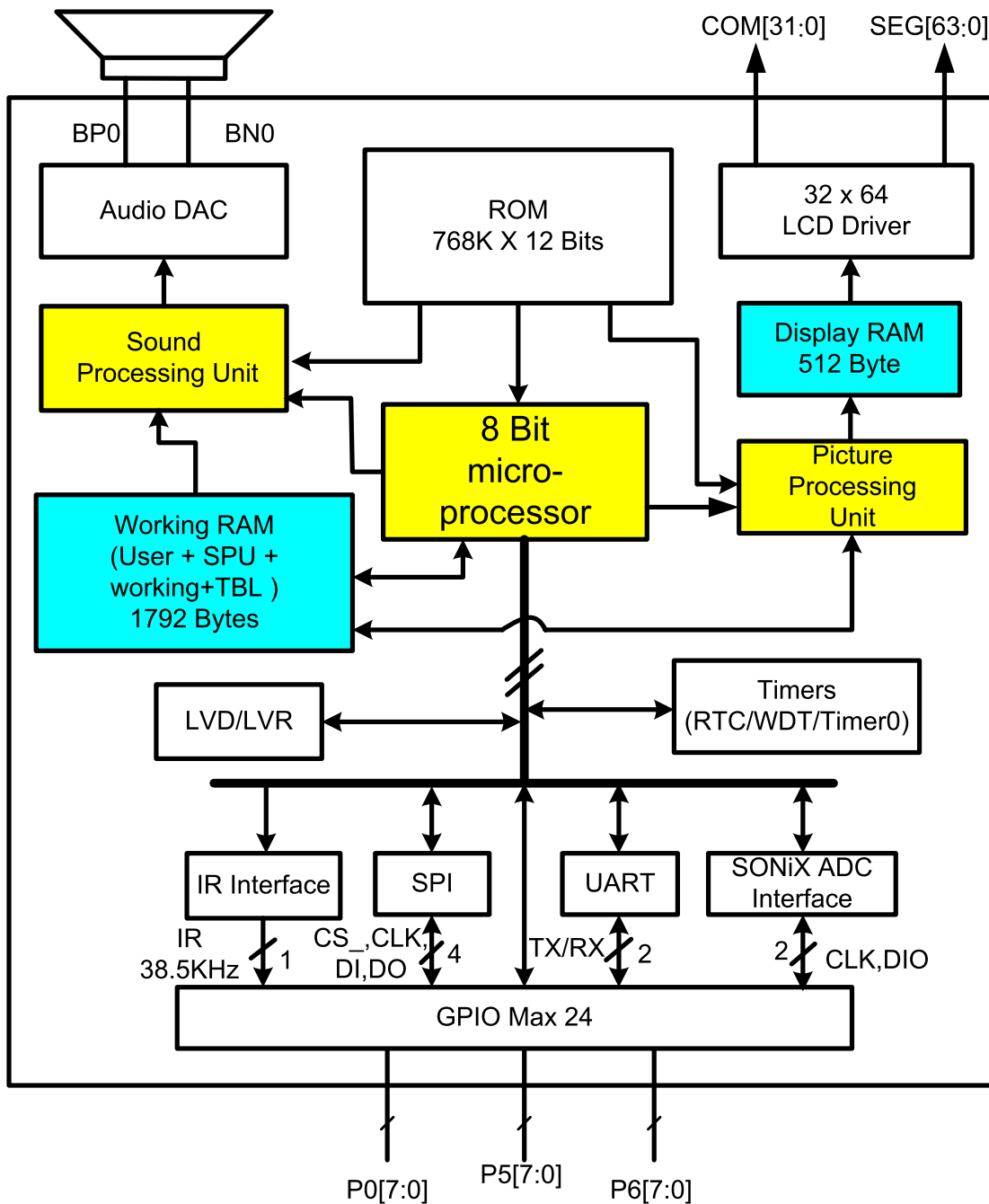

5 FUNCTION DESCRIPTION

5.1. ROM

SNL261 contains a substantial 768k x12 bits internal ROM which is shared by program and resource data. Program, voice, melodies, data, images and instrument waveforms are shared within this same ROM area.

5.2. RAM

SNL261 contains 2304 bytes RAM. The 2304 bytes RAM is divided into 20 pages (128 bytes RAM for each page). The RAMBK register is used to switch to a specific RAM page. For example, declaring

```
Org      0x280
UseMem  ds  1
```

would locate one byte memory for "User RAM" at BANK 4. Setting 'RAMbk = 5' in a program would switch to bank 5 of RAM.

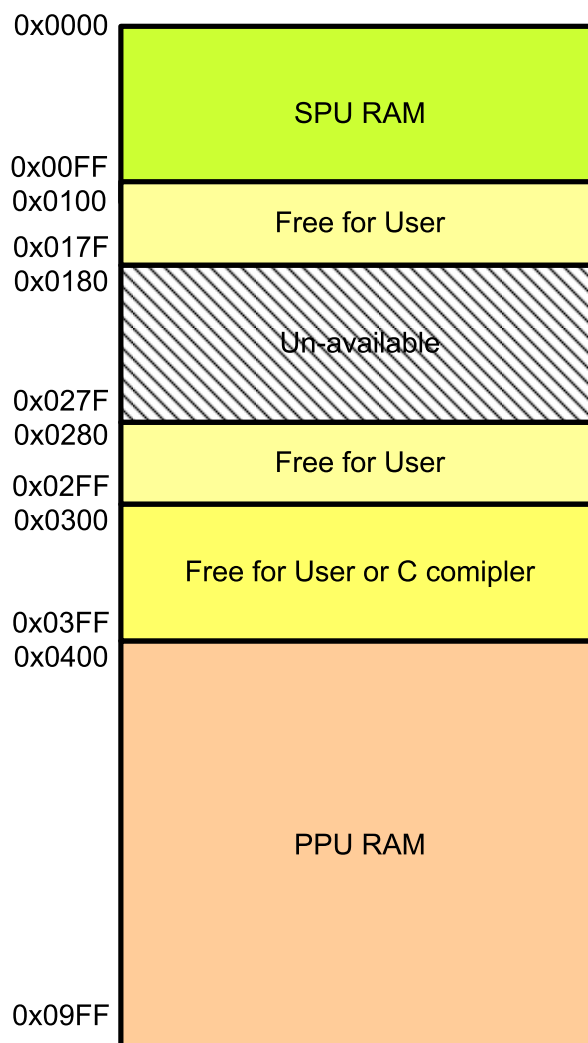

5.3. Interrupt

SNL261 provides 8 interrupt sources; include Timer0, PPU, ADINT, SPI, UART, AKINT and WaveMark. When CPU enters an interrupt service routine, the GIE bit (in INTEN) will be cleared to "0". Any other interrupt requests will not be granted at this time. Instead, these requests will be queued in INTRQ.*IRQ, and will be served once GIE is restored to "1" The GIE will be restored to 1 once the CPU exits the ISR.

5.4. Operation Mode

There are four different operation modes in SNL261.

Normal Mode : Hi-speed clock ON, chip works normally at 16MHz.

Slow Mode : Low-speed clock ON, chip works normally at 32kHz.

Idle Mode : Low-speed clock ON, chip is halt.

Sleep Mode : Hi and Low speed clock Off, chip is halt.

5.5. I/O Ports

There are three 8-bit I/O ports those are P0, P5 and P6. All ports are dedicated I/O pins, P0, P5 and P6 can be individually programmed as either input or output. Any valid data transition (H→ L or L→H) of each I/O port can wake-up the chip from power-down mode.

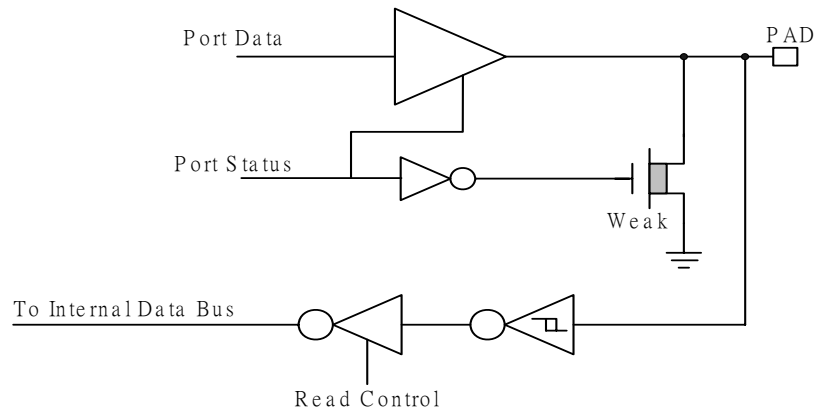

I/O Port Configuration

Note: weak N-MOS's can serve as pull-low resistors.

5.6. Watch Dog Timer

SNL261 built in an internal WDT (Watch Dog Timer). This Watchdog timer would issue resets signal to this chip if it is not cleared before reaching terminal count (1sec). The watchdog timer is enabled at reset and cannot be disabled.

5.7. Timer

The timers consist of a pre-scalar, and an 8-bit Up-counting counter with an auto-reload function. The 4-bit pre-scalar is used as clock division. If a successful event occurs (counting value = setting value), it will issue an interrupt request and continue counting. The clock source of the pre-scalar is system clock /2

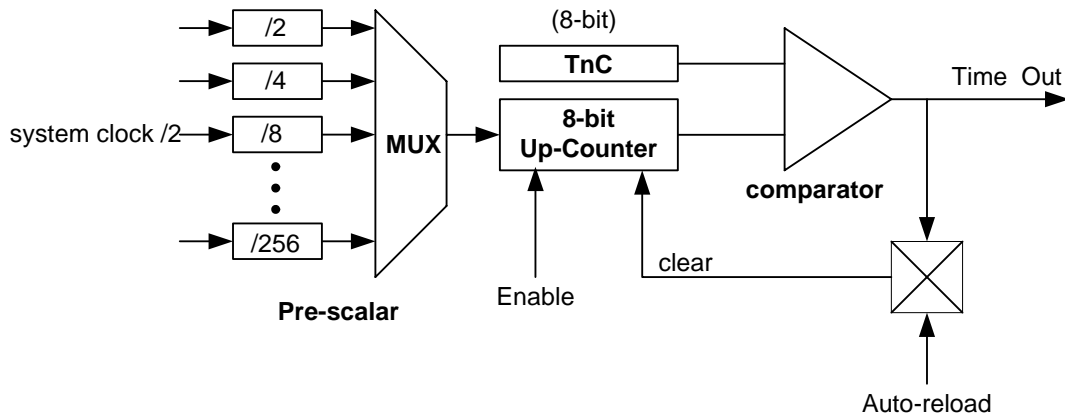

5.8. UART

The SNL261 provides a standard UART interface, and users can download data from PC through this UART interface.

5.9. Serial Peripheral Interface (SPI)

The SPI (serial peripheral interface) is a synchronous serial bus that provides good support for communication with SPI-compatible peripheral devices, such as serial EEPROM, serial flash, and etc.

5.10. PWM IO control

SNL261 supports 4 PWM IO (P5.3 ~ P5.6) output. Each I/O has 8 bits independent duty register.

5.11. Voltage detector

The SNL261 has a Low Voltage Detector (LVD) for power management usage. The status of supplying power can be detected and monitored from 2.4V to 2.8V.

5.12. Auto Scan Key Function

The COM 0~31 can be used for LCD display and at the same time as keyboard scan output. Combine with port 6 serve as keyboard scan input. Maximum 16 * 8 keypads (128 keys) can be used for application.

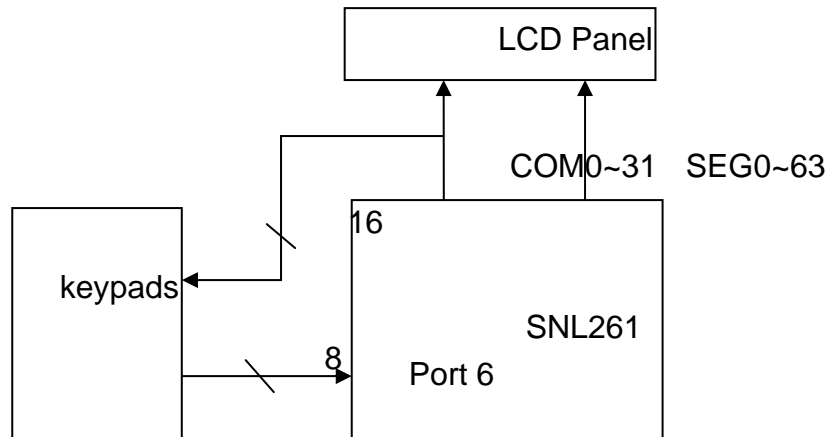

As shown above, the COM0~31 are used for COM output and at the same time served as keypads output while keyboard scan function is enabled.

5.13. Picture Processing Unit (PPU)

The SNL261 built in a picture processing unit can process up to 85 objects and display on the LCD accordingly. With the help of PPU user can focus on the gaming flow and left the hassle of pixel alignment, object movement, scrolling... etc, to PPU. Besides, all the frame data which PPU generate can be editing by user before display on LCD. With this flexibility, user can then handle some objects to enhance some special effects regardless of H/W PPU limitation.

5.14. Sound Processing Unit (SPU)

The Sound Processing Unit (SPU) in SNL261 provides up to 16 voice/music channels. A high-performance multi-channel music synthesizer is built-in to provide high-quality wave-table melody playback. Most of standard MIDI format can be accessed through the MIDI to Melody convert software. The voice playing can support 10-bit PCM, 6-bit ASDPCM and 4-bit ASDPCM compression format. Each channel has its own volume control and has a main volume control as well.

5.14.1 Sampling Rate Counters

Each voice channel of 16 is equipped with an independent sampling rate counter to allow individual sample rate play back per channel. Channel sample rate play back can be dynamically set from 4KHz to 64KHz (@16MHz). Each sampling rate counter is updated on a period of 0.125uS. This architecture yields a high-quality music/voice synthesis that sounds very close to its original source when played through the same amplifier and speaker circuitry.

5.14.2 Auto Repetition

Each voice channel of 16 is equipped with a hardware auto repeat function. Auto repeat functions are normally used to implement sustain in instrument synthesis but can even be used to repeat any voice data of arbitrary length.

5.14.3 Voice Synthesizer

The Major function of Voice Synthesizer is to fetch Wave data from ROM and synthesize into voice. Each voice channel of 16 is equipped with an individual volume setting.

6 APPLICATION CIRCUIT

- ◆ Power Supply: 3.0V
- ◆ System Clock: 16M IHRC
- ◆ Low Clock: 32768 X'TAL
- ◆ Voice output: Push Pull DAC Output

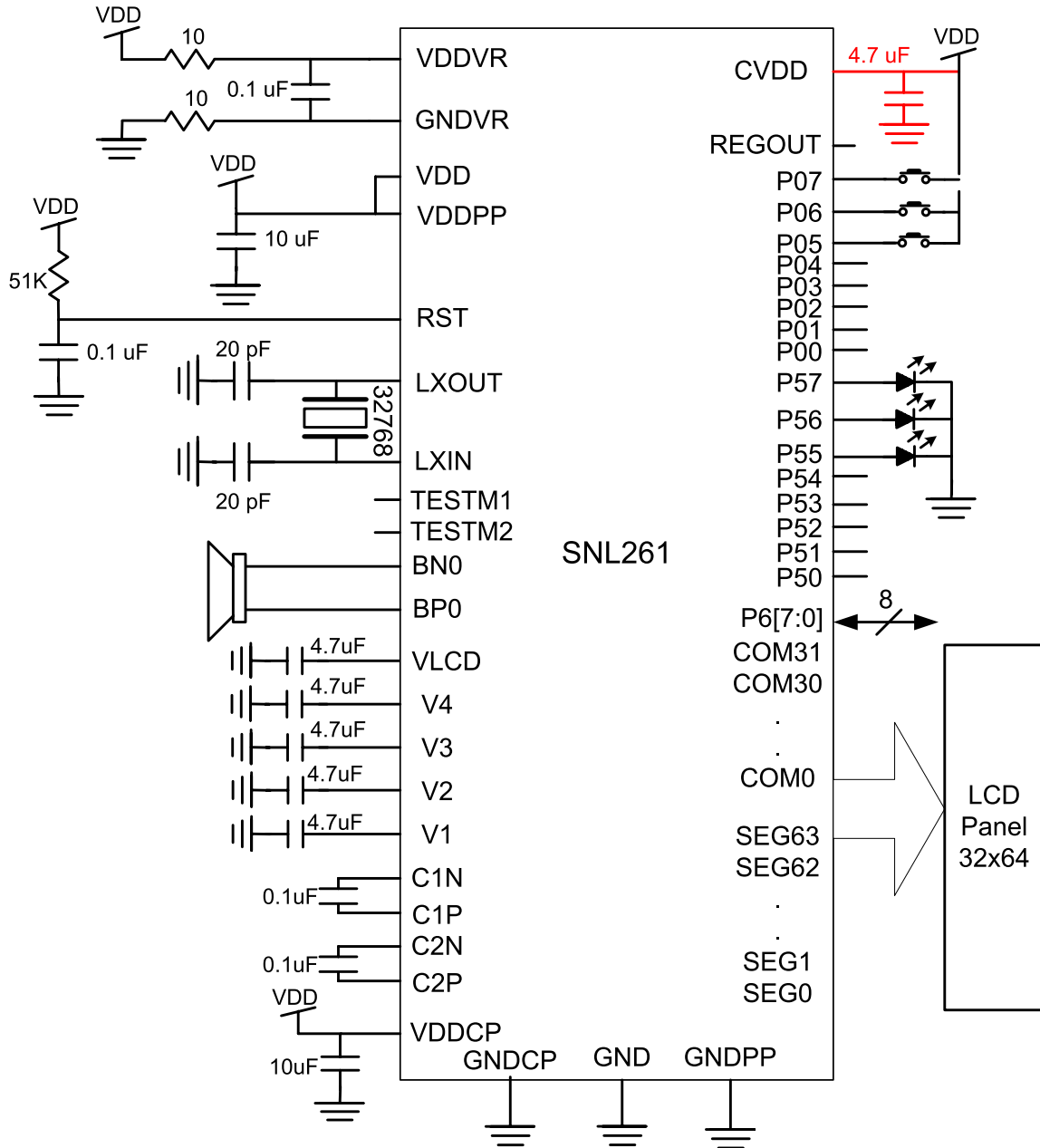

- ◆ Power Supply: 4.5V
- ◆ System Clock: 16M IHRC
- ◆ Low Clock: 32768 X'TAL
- ◆ Voice output: Push Pull DAC Output

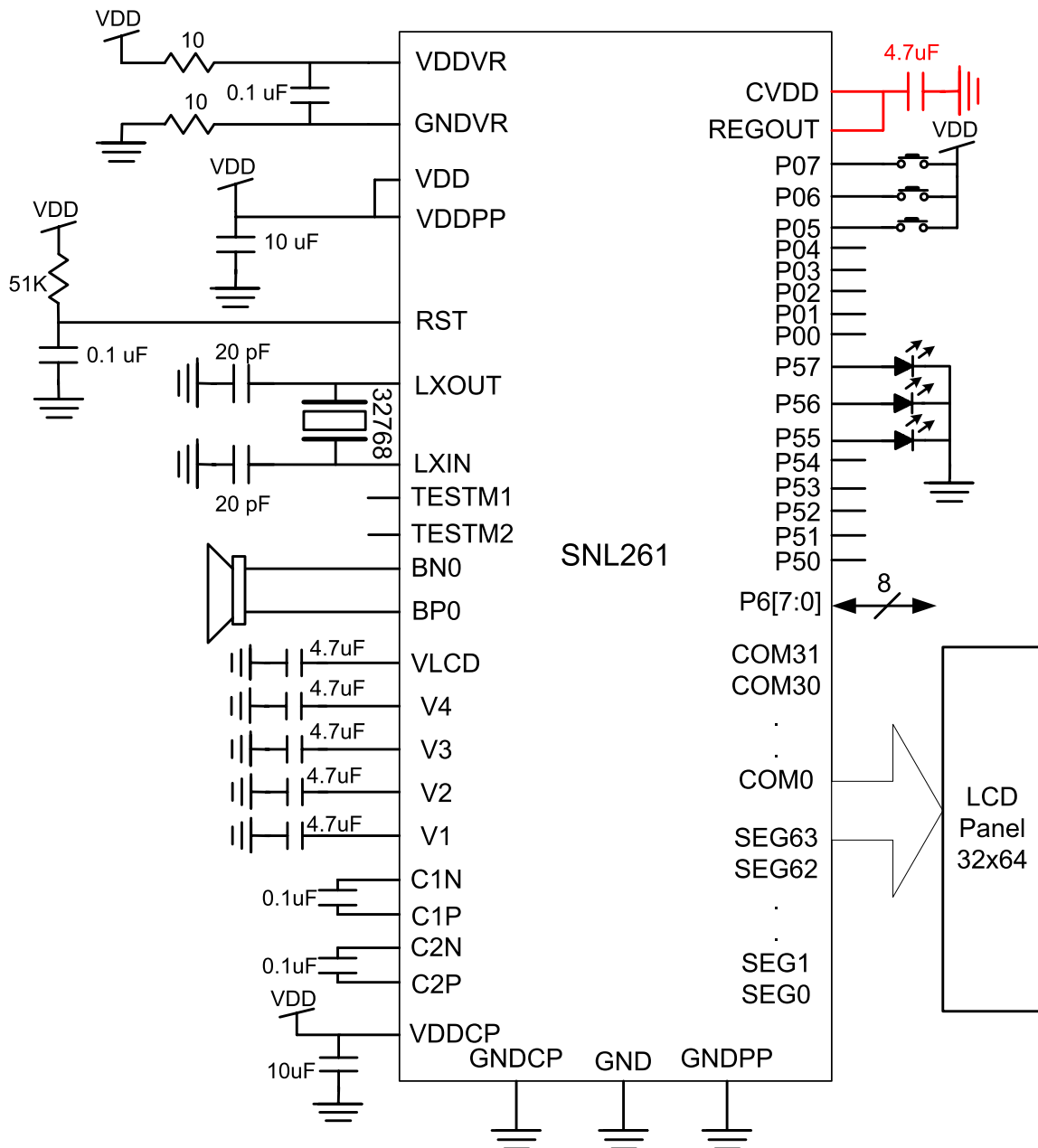

◆ HW Auto Scan Key

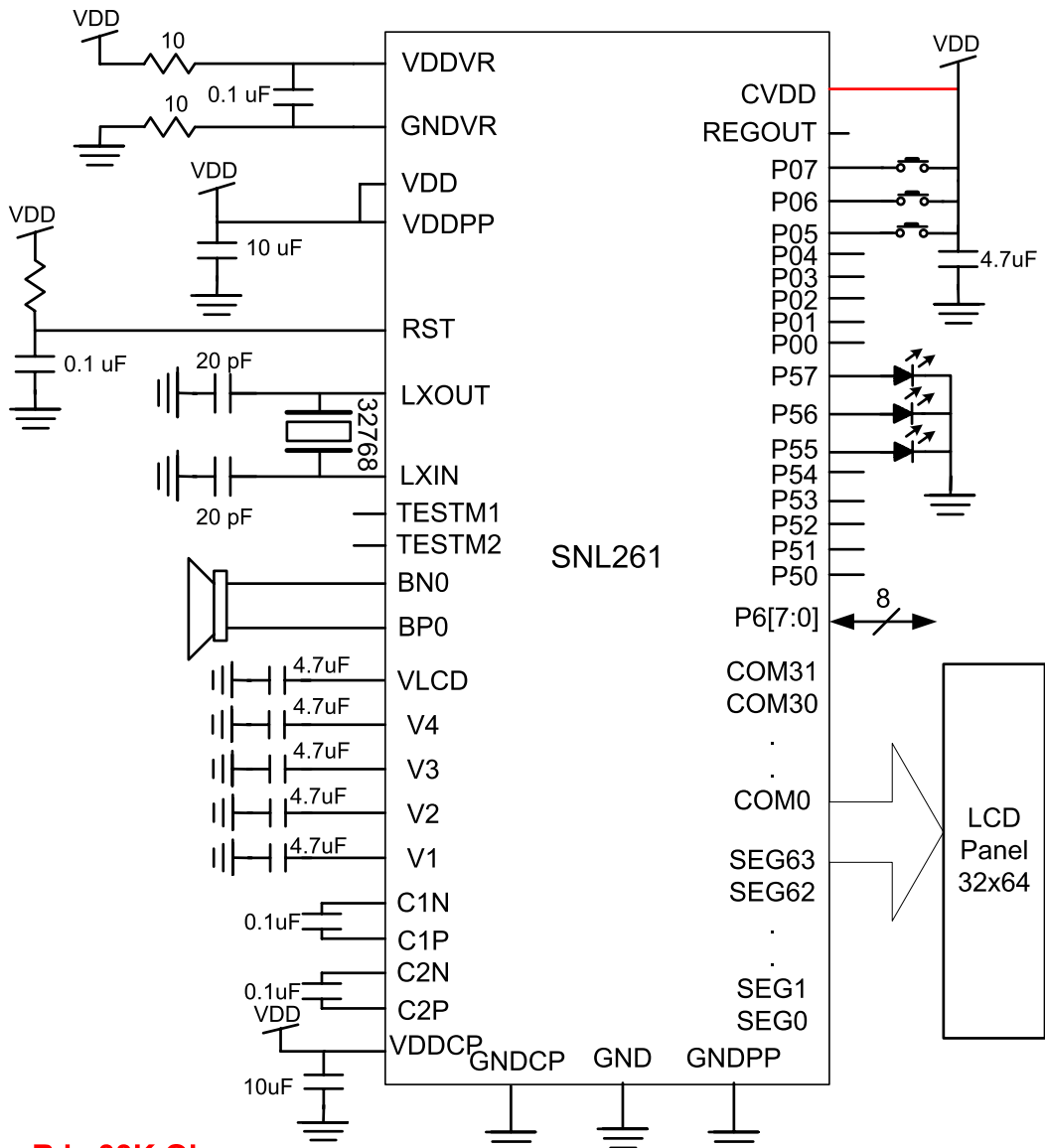

Note R is 33K Ohm

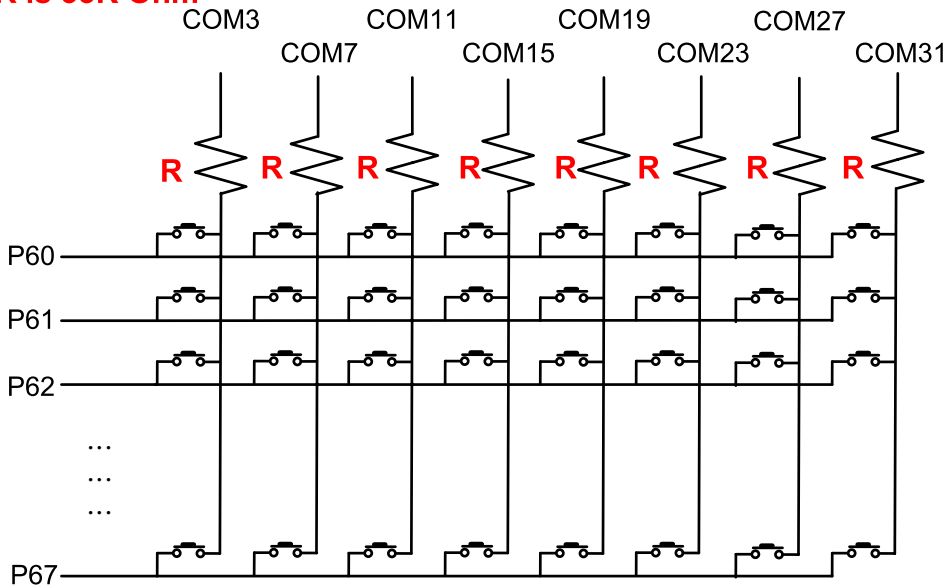

7 ABSOLUTE MAXIMUM RATING

Items	Symbol	Min	Max	Unit.
Supply Voltage	V_{DD-V}	-0.3	6.0	V
Input Voltage	V_{IN}	$V_{SS}-0.3$	$V_{DD}+0.3$	V
Operating Temperature	T_{OP}	0	55.0	°C
Storage Temperature	T_{STG}	-55.0	125.0	°C

8 ELECTRICAL CHARACTERISTICS

Item	Sym.	Min	Typ.	Max	Unit	Condition
Operating Voltage	V_{DD}	2.4	-	5.1	V	
Standby Current 1	I_{SBY}	-	3	-	μA	$V_{DD}=3V$
Standby Current 2	I_{SBY}	-	5	-	μA	$V_{DD}=5V$
Normal mode operating current	I_{NOPR}	-	6	-	mA	$V_{DD}=3V$, no load, push pull turned off. Execute "NOP" instruction
Slow mode operating current	I_{SOPR}	-	15	-	μA	$V_{DD}=3V$, CPU clock is 32 KHz, Push Pull off, LCD driver off
Idle mode operating current 1	I_{SOPR}	-	50	-	μA	$V_{DD}=3V$, CPU halt, Push-Pull off, LCD driver on, without panel.
Idle mode operating current 2	I_{SOPR}	-	5	-	μA	$V_{DD}=3V$, CPU halt, Push-Pull off, LCD driver off
Input pull low impedance of P0,P5,P6	R_i	-	1M	-	Ω	$V_{DD}=3V$
P0, P5, P6 Drive Current	I_{OD}	-	4	-	mA	$V_{DD}=3V$, $V_O=2.4V$
P0, P5, P6 Sink Current	I_{OS}	-	6	-	mA	$V_{DD}=3V$, $V_O=0.4V$
Low voltage Reset (LVR)			1.8		V	
Push-Pull current	I_{PP}	-	70	-	mA	$V_{DD}=3V$, Output 1Khz Sin wave.
LCD driver voltage	V_{LCD}		5.73		V	$\pm 5\%$ @ $V_{DD}=5V$, LCDREG register = 0x74, No load
Frequency shift	R_{osc}		16.384		MHz	$\pm 3\%$ @ 3V
Input Low voltage	V_{IL}	V_{SS}	-	0.3* V_{DD}	V	
Input high voltage	V_{IH}	0.7* V_{DD}	-	V_{DD}	V	

9 System high-clock

The system high-clock source is from the internal high-speed oscillator built in the SNL200 chip. The high-speed oscillator uses RC type oscillator circuit. The frequency is affected by the voltage and temperature of the system and the following two diagrams is shown up the relation.

The figure <9-1> shows up the relationship between the high-clock frequency and temperature.

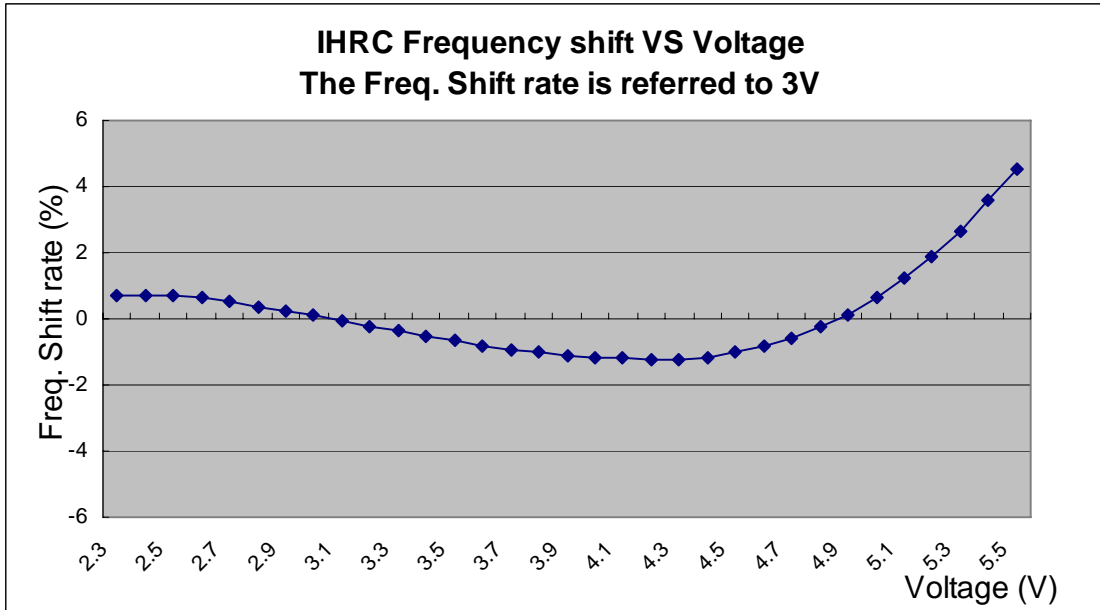

Figure <9-1>

The Figure <9-2> shows up the relationship between the high-clock frequency and temperature.

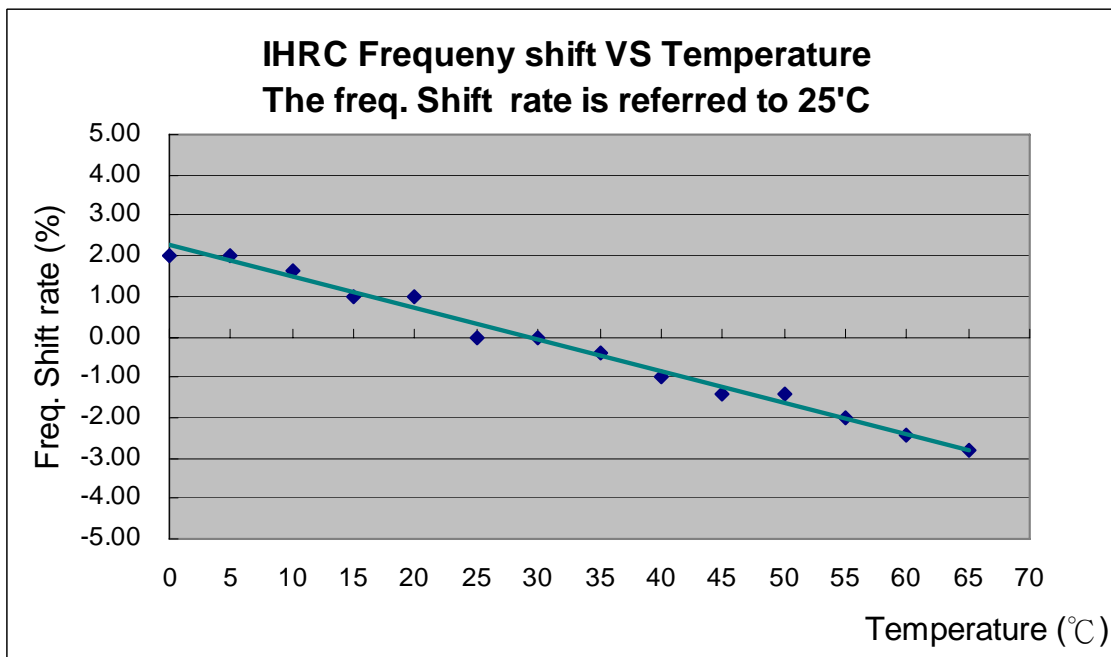

Figure <9-2>

10 VLCD power

The VLCD power of SNL200 series is 32 steps adjustable. The range of VLCD power can be from 4.2 to 6.5V through setting LCDREG register.

In addition to that user sets LCDREG register will affect VLCD power, VLCD power also will be affected by variation VDD voltage. The following diagram **figure <10-1>** is shown up the relationship between VDD and VLCD power.

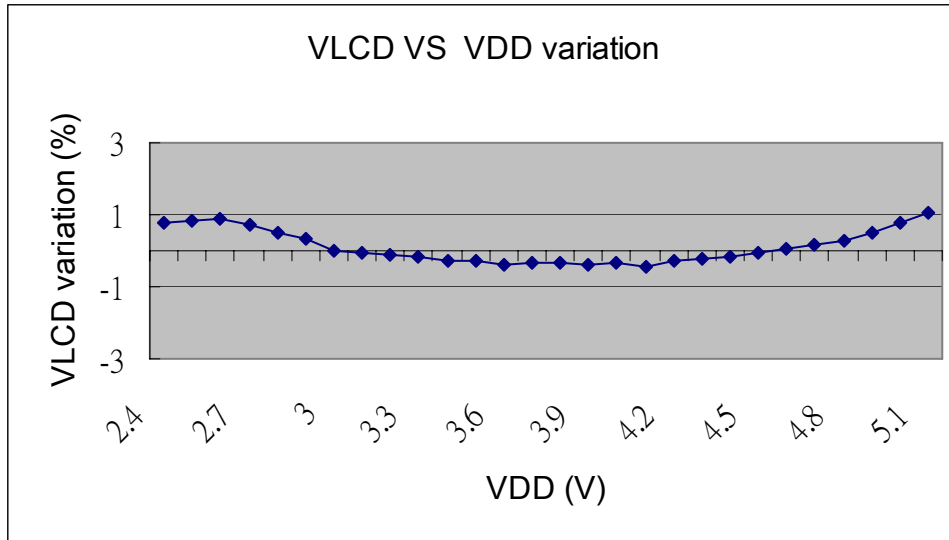

Figure <10-1>

DISCLAIMER

The information appearing in SONiX web pages (“this publication”) is believed to be accurate.

However, this publication could contain technical inaccuracies or typographical errors. The reader should not assume that this publication is error-free or that it will be suitable for any particular purpose. SONiX makes no warranty, express, statutory implied or by description in this publication or other documents which are referenced by or linked to this publication. In no event shall SONiX be liable for any special, incidental, indirect or consequential damages of any kind, or any damages whatsoever, including, without limitation, those resulting from loss of use, data or profits, whether or not advised of the possibility of damage, and on any theory of liability, arising out of or in connection with the use or performance of this publication or other documents which are referenced by or linked to this publication.

This publication was developed for products offered in Taiwan. SONiX may not offer the products discussed in this document in other countries. Information is subject to change without notice. Please contact SONiX or its local representative for information on offerings available. Integrated circuits sold by SONiX are covered by the warranty and patent indemnification provisions stipulated in the terms of sale only. The application circuits illustrated in this document are for reference purposes only. SONiX DISCLAIMS ALL WARRANTIES, INCLUDING THE WARRANTY OF MERCHANTABILITY OR FITNESS FOR ANY PURPOSE. SONiX reserves the right to halt production or alter the specifications and prices, and discontinue marketing the Products listed at any time without notice. Accordingly, the reader is cautioned to verify that the data sheets and other information in this publication are current before placing orders.

Products described herein are intended for use in normal commercial applications. Applications involving unusual environmental or reliability requirements, e.g. military equipment or medical life support equipment, are specifically not recommended without additional processing by SONiX for such application.