



===== **CONTENTS** =====

1	INTRODUCTION.....	3
2	FEATURES	3
3	PIN ASSIGNMENT	4
4	BLOCK DIAGRAM	5
5	FUNCTION DESCRIPTION.....	6
5.1.	ROM.....	6
5.2.	RAM.....	6
5.3.	POWER DOWN MODE.....	7
5.4.	IR FUNCTION.....	7
5.5.	I/O PORTS	7
5.6.	SAMPLING RATE COUNTERS.....	8
5.7.	WAVE PROCESSING UNIT (WPU).....	8
5.8.	AUTO REPETITION	8
5.9.	SYSTEM CLOCK	9
5.10.	SERIAL PERIPHERAL INTERFACE (SPI)	10
5.11.	PWMIO	10
5.12.	VOLUME CONTROL	10
6	APPLICATION CIRCUIT.....	11
7	ABSOLUTE MAXIMUM RATING.....	13
8	ELECTRICAL CHARACTERISTICS	13



AMENDMENT HISTORY

Version	Date	Description
Ver 1.0	Dec 15, 2009	First issue
Ver 1.1	Jan 11, 2010	Update the relationship between the high-clock frequency and temperature.



1 INTRODUCTION

The SNC82200B is a single chip 12-channel MIDI compatible wave-table/voice synthesizer. Equipped with a powerful 8-bit controller and 24 I/O pins, it provides a low-cost MIDI sound system solution. It's low power consumption and operating range makes it ideal for all battery operated devices using MIDI or voice synthesis.

2 FEATURES

- ◆ Single Power Supply 2.4V – 5.1V
- ◆ Powerful Built-in 8-bit Controller
- ◆ Three 8-bit I/O ports
- ◆ 384*8 bits RAM
- ◆ Maximum 256k program ROM
- ◆ 408K*15 bits shared ROM for program and voice data
- ◆ One 12-bits Push-pull DAC with 64-levels global (analog) volume control
- ◆ Support 5-bits ASDPCM & 12-bits PCM
- ◆ System clock: internal OSC 16.384Mhz $\pm 3\%$
- ◆ Serial Peripheral Interface (SPI) is provided
- ◆ Support play wave from SPI flash
- ◆ Support 4 PWMIO functions – Each PWMIO has 8-bit independent duty register.
- ◆ ESD improved
- ◆ Support SF2 ADSR envelope control
- ◆ 12-voice Polyphony through a high-quality speech synthesizer
- ◆ Mark Event Supported in both Wave and Melody
- ◆ Support wave mark interrupt
- ◆ Maximum 4096 wave mark
- ◆ Individual adaptive playing speed from 4k-64kHz for all 12 channels
- ◆ Automatic repetition for each channel
- ◆ Volume modulation controlled by embedded multiplier
- ◆ One digital mixers with saturation control
- ◆ Analog Direct Drive speaker circuit
- ◆ 2 MIPS CPU power free to user
- ◆ Low Voltage Reset
- ◆ Built-in a 8*8 Multiplex for CPU
- ◆ 2 Timers, WDT and Tick timer
 - Timers 0 with Individual pre-scaler and auto-reload function, Timer 0 with Interrupt Function
 - Timers 1 with selectable time out (1ms, 4ms, 8ms, 16ms)
 - Watch Dog timer function is provided
 - Built-in a tick timer for software melody decodes



3 PIN ASSIGNMENT

Symbol	I/O	Function Description
P00 ~ P07	I/O	Bit7 ~ Bit0 of I/O port 0
P10 ~ P17	I/O	Bit7 ~ Bit0 of I/O port 1
P20 ~ P27	I/O	Bit7 ~ Bit0 of I/O port 2
VDDPP	P	Positive power supply for Direct Drive
GNDPP	P	Negative power supply for Direct Drive
CVDD	P	Positive power supply for internal circuit
VDD	P	Positive power supply for I/O
GND	P	Negative power supply
REGOUT	P	3V regulator output
RST	I	Chip Reset (Active low)
TestM	I	Test Pin
BN0	O	Direct Drive negative output
BP0	O	Direct Drive positive output

4 Block Diagram

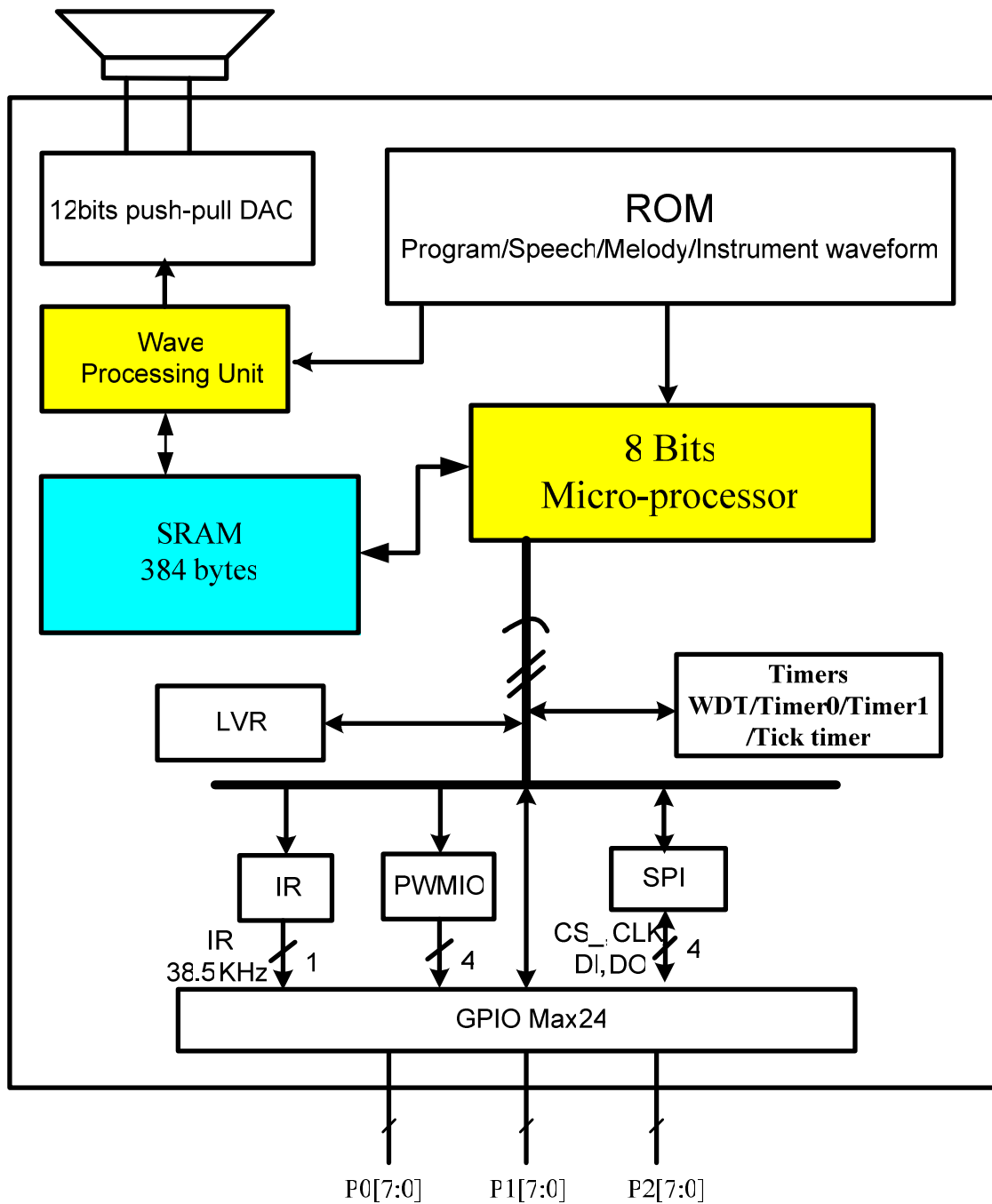

5 FUNCTION DESCRIPTION

5.1. ROM

SNC82200B contains a substantial 408K*15 bits internal ROM which is shared by program and resource data. Program, voice, melodies, data, and instrument waveforms are shared within this same 408K*15 bits ROM.

5.2. RAM

SNC82200B contains 384 bytes RAM (384 x 8-bits). The 384 byte RAM is divided into five pages (page0, 1 and 4, 128 bytes RAM for each page).

```
Org      0x250
UseMem  ds  1
```

Need not select RAMBK in directly addressing mode

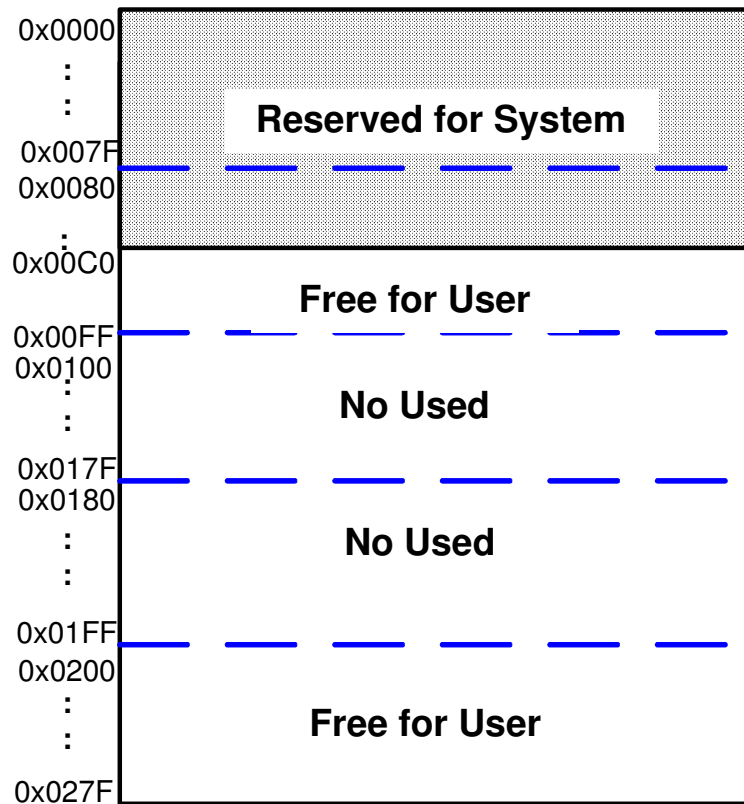

Notice: (C0~FFh) and (200~27Fh) Bank4 is free for user.

5.3. Power Down Mode

Entering the IC into Stop Mode will stop the system clock for power savings (<3uA @VDD=3V and <6uA @VDD=4.5V). Any transition (L→H or H→L) on any I/O pin can be used to start the system clock and return to normal operating mode.

5.4. IR Function

When IR is enabled, a 38.5KHz square wave is gated with P27. The 38.5KHz IR signal is present at the pin when P27 is set to "1".

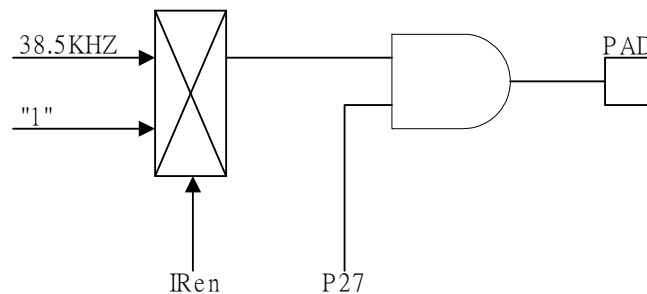

5.5. I/O Ports

There are three 8-bit I/O ports P0, P1, and P2. Any I/O can be individually programmed as either input or output. When I/O is set to input, any valid data transition (H→ L or L→H) of each I/O port can wake-up the chip from power-down mode.

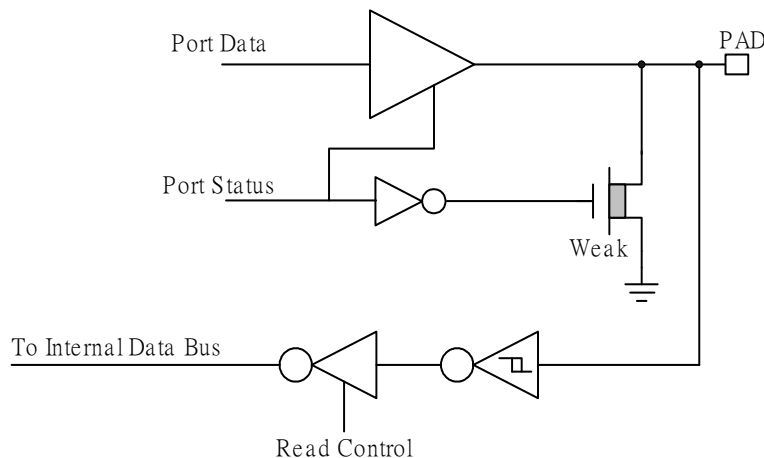

I/O Port Configuration

Note: weak N-MOS's can serve as pull-low resistors.



5.6. Sampling Rate Counters

Each voice channel of 12 is equipped with an independent sampling rate counter to allow individual sample rate play back per channel. Channel sample rate play back can be dynamically set from 4KHz to 64KHz. Each sampling rate counter is updated on a period of 0.125uS. This architecture yields a high-quality music/voice synthesis that sounds very close to its original source when played through the same amplifier and speaker circuitry.

5.7. Wave Processing Unit (WPU)

The Wave Processing Unit (WPU) in SNC82200B provides up to 12 voice/music channels. A high-performance multi-channel music synthesizer is built-in to provide high-quality wave-table melody playback. Most of standard MIDI format can be accessed through the MIDI to Melody convert software. The voice playing can support 12-bits PCM and 5-bits ASDPCM compression format. Each channel has its own volume control and has a main volume control as well.

5.8. Auto Repetition

Each voice channel of 12 is equipped with a hardware auto repeat function. Auto repeat functions are normally used to implement sustain in instrument synthesis but can even be used to repeat any voice data of arbitrary length.

5.9. System clock

The system clock source is from the internal high-speed oscillator built in the SNC82200B chip. The high-speed oscillator uses RC type oscillator circuit. The frequency is affected by the voltage and temperature of the system and the following two diagrams is shown up the relation.

The figure <5-1> shows up the relationship between the high-clock frequency and Voltage.

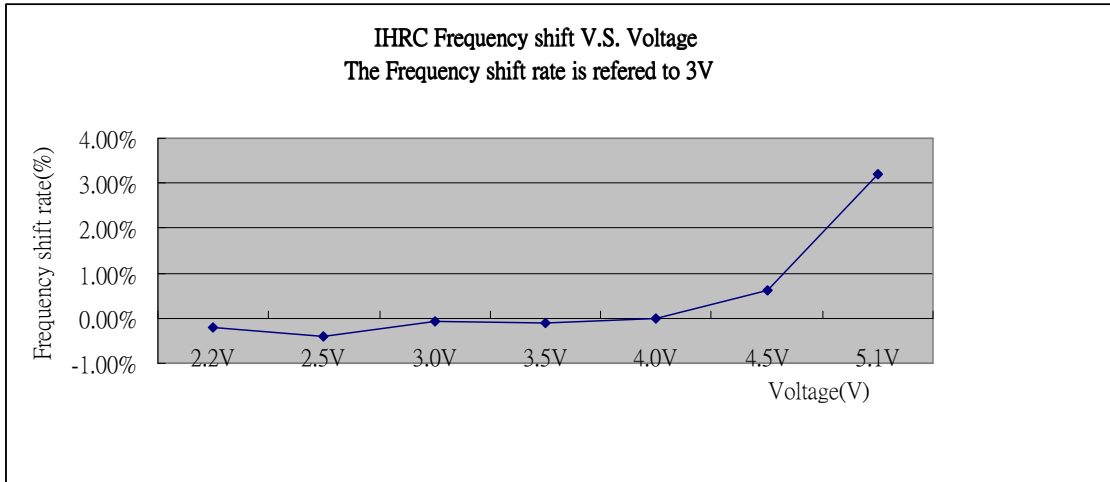

Figure <5-1>

The Figure <5-2> shows up the relationship between the high-clock frequency and temperature at VDD=3V.

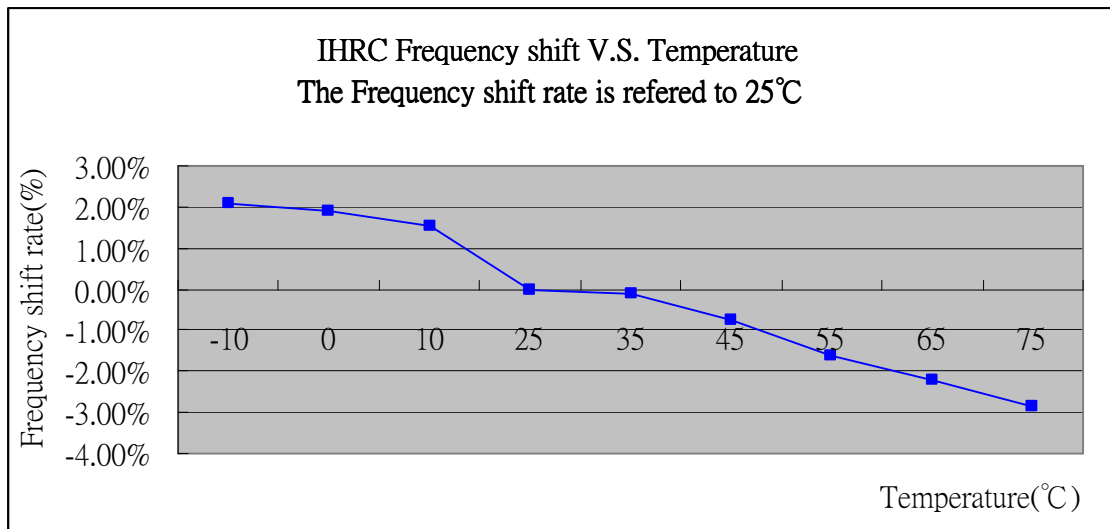

Figure <5-2>

5.10. Serial Peripheral Interface (SPI)

The SPI (serial peripheral interface) is a synchronous serial bus that provides good support for communication with SPI-compatible peripheral devices, such as serial EEPROM, serial flash, and etc.

5.11. PWMIO

SNC82200B have support 4 PWMIO (**P2.0, P2.1, P2.2, P2.7**). Each I/O has 8-bit independent duty register, and the 8-bit register are comparing with 8 bits counter. If set use PWM IO function and internal counter start at 000H, the mapping I/O will set High. The 8 bits counter increment until the corresponding duty register, and then will reset the mapping IO pin.

5.12. Volume Control

There are three ways to control volume of SNC80000B which is **channel volume control (8bits)**, **Analog global volume control** and **Digital global volume control**.

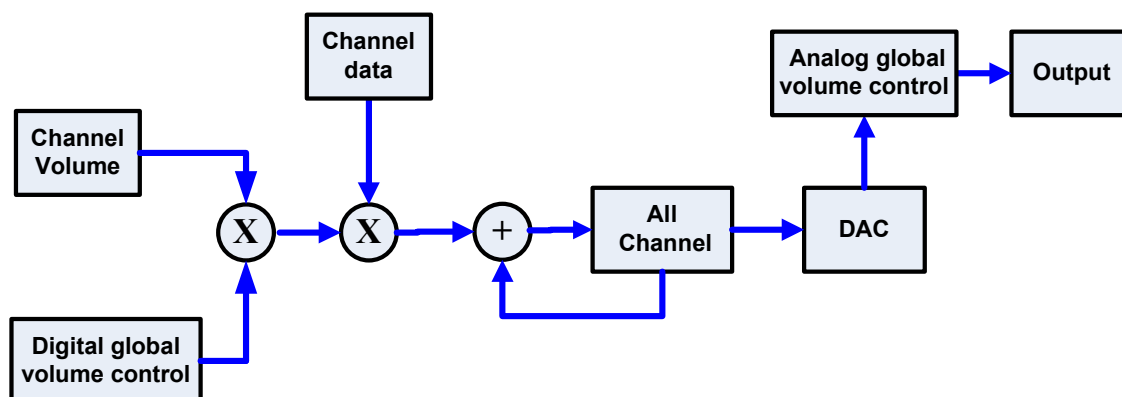

6 APPLICATION CIRCUIT

- ◆ Power Supply: 3.0V
- ◆ System Clock: Rosc 16.384Mhz ($\pm 3\%$)
- ◆ Voice output: Direct Drive Output

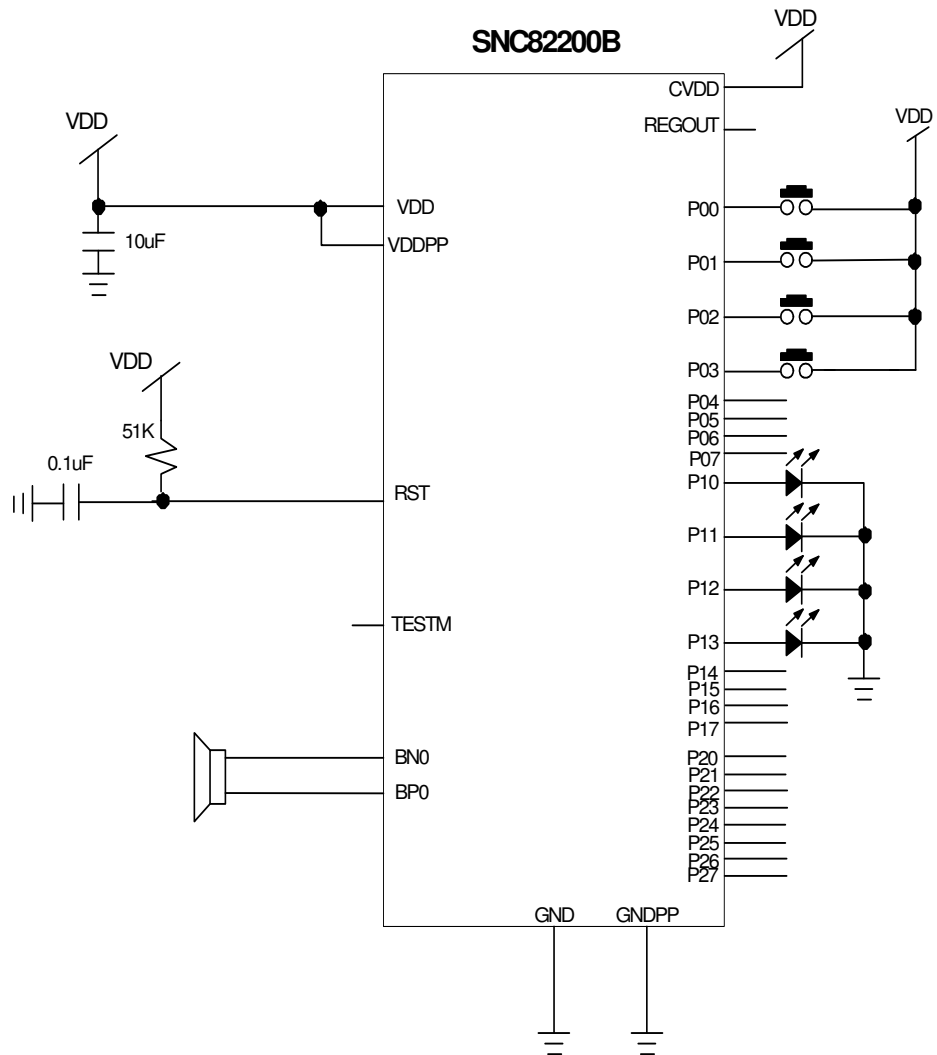

- ◆ Power Supply: 4.5V
- ◆ System Clock: Rosc 16.384Mhz ($\pm 3\%$)
- ◆ Voice output: Direct Drive Output

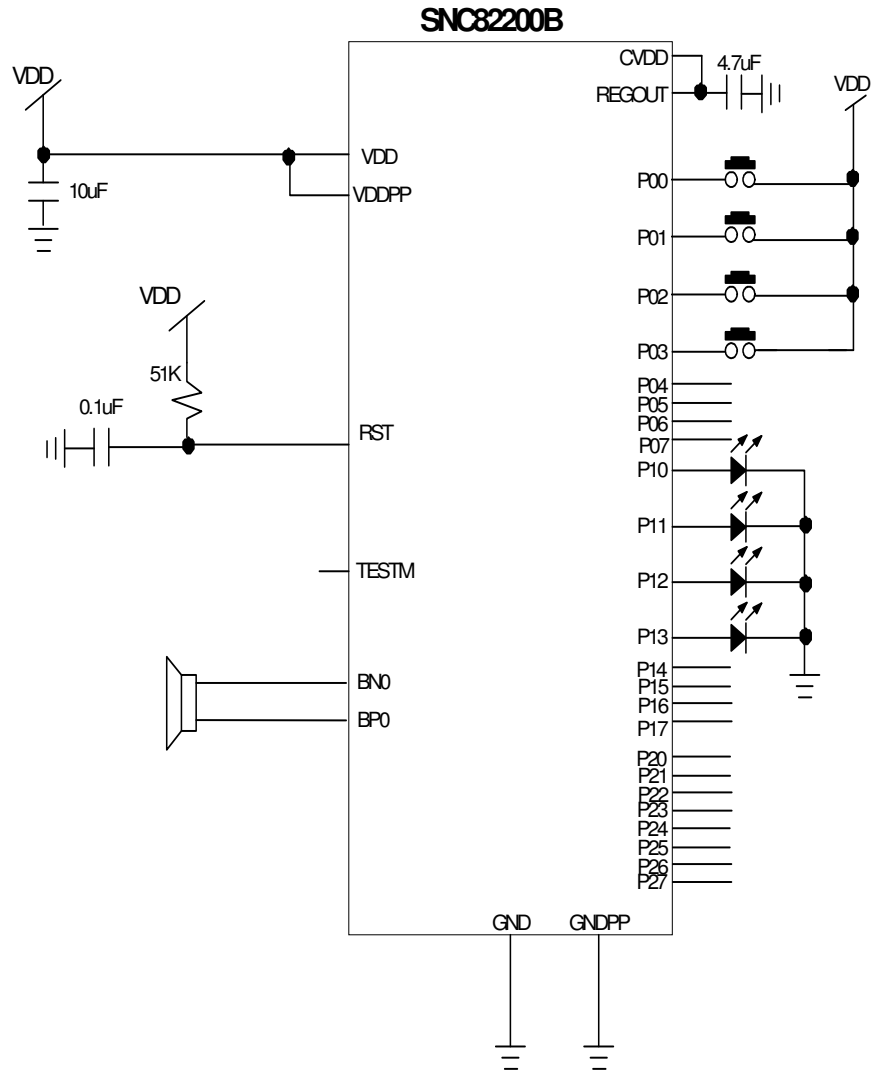



7 ABSOLUTE MAXIMUM RATING

Items	Symbol	Min	Max	Unit.
Supply Voltage	V_{DD-V}	-0.3	6.0	V
Input Voltage	V_{IN}	$V_{SS}-0.3$	$V_{DD}+0.3$	V
Operating Temperature	T_{OP}	0	55.0	°C
Storage Temperature	T_{STG}	-55.0	125.0	°C

8 ELECTRICAL CHARACTERISTICS

Item	Sym.	Min.	Typ.	Max.	Unit	Condition
Operating Voltage	V_{DD}	2.4	-	5.1	V	
Standby Current	I_{SBY}	-	3 5	-	μA	$V_{DD}=3V$ $V_{DD}=4.5V$
Operating Current (Push-Pull Turn On)	I_{OPR}	-	6 12	-	mA	$V_{DD}=3V$, no load $V_{DD}=4.5V$, no load
Operating Current (Push-Pull Turn OFF)	I_{OPR}	-	4 5	-	mA	$V_{DD}=3V$, no load $V_{DD}=4.5V$, no load
Input pull low impedance of P0~P3	R_i	-	0.8M	-	Ω	$V_{DD}=3V$
I/O port Drive Current	I_{OD}	-	4 8	-	mA	$V_{DD}=3V$, $V_O=2.6V$ $V_{DD}=5V$, $V_O=4.2V$
I/O port Sink Current	I_{OS}	-	6 10	-	mA	$V_{DD}=3V$, $V_O=0.4V$ $V_{DD}=5V$, $V_O=0.8V$
Push-Pull current	I_{PP}	-	70	-	mA	$V_{DD}=3V$, Output 1Khz Sin wave.
Push-Pull current	I_{PP}	-	100	-	mA	$V_{DD}=4.5V$, Ouput 1Khz Sin wave.
IR Carrier Frequency	F_{IR}	-	38.5	-	KHz	
Internal ROOSC Frequency	F_{OSC}	15.892	16.384	16.876	Mhz	$V_{DD}=3V(\pm 3\%)$

DISCLAIMER

The information appearing in SONiX web pages (“this publication”) is believed to be accurate.

However, this publication could contain technical inaccuracies or typographical errors. The reader should not assume that this publication is error-free or that it will be suitable for any particular purpose. SONiX makes no warranty, express, statutory implied or by description in this publication or other documents which are referenced by or linked to this publication. In no event shall SONiX be liable for any special, incidental, indirect or consequential damages of any kind, or any damages whatsoever, including, without limitation, those resulting from loss of use, data or profits, whether or not advised of the possibility of damage, and on any theory of liability, arising out of or in connection with the use or performance of this publication or other documents which are referenced by or linked to this publication.

This publication was developed for products offered in Taiwan. SONiX may not offer the products discussed in this document in other countries. Information is subject to change without notice. Please contact SONiX or its local representative for information on offerings available. Integrated circuits sold by SONiX are covered by the warranty and patent indemnification provisions stipulated in the terms of sale only.

The application circuits illustrated in this document are for reference purposes only. SONiX DISCLAIMS ALL WARRANTIES, INCLUDING THE WARRANTY OF MERCHANTABILITY OR FITNESS FOR ANY PURPOSE. SONiX reserves the right to halt production or alter the specifications and prices, and discontinue marketing the Products listed at any time without notice. Accordingly, the reader is cautioned to verify that the data sheets and other information in this publication are current before placing orders.

Products described herein are intended for use in normal commercial applications. Applications involving unusual environmental or reliability requirements, e.g. military equipment or medical life support equipment, are specifically not recommended without additional processing by SONiX for such application.