



## 1. INTRODUCTION

SNC735 is a 32mins two-channel speech/melody and 4-channel wave-table melody voice chip. It based on reduced 16-bit fixed-point DSP architecture. SNC735 provides user some necessary and efficient DSP instructions. Furthermore, SNC735 provide one 10-bit PWM and one 10-bit DA converter to driving speaker for speech/melody output. User can select PWM or DA by programming DA/PWM control register, and only one function can be active at the same time.

## 2. FEATURES

- ◆ Power supply: 2.4V ~ 3.6V (for 2 battery application)  
3.6V ~ 5.1V (for 3 battery application)
- ◆ Built-in a 16-bit DSP (Very Light Structure)
- ◆ Software-based voice/melody processing
- ◆ Rich Function Instruction Set
- ◆ System Clock
  - 16MHz crystal or R-C type oscillator for system clock
  - 0.25s real time clock is form 32768Hz crystal
- ◆ 8 MIPS CPU performance
- ◆ I/O Ports:
  - 16 I/O pins (P0.0~P0.15) and 8 input pins (P1.0~P1.7)
  - P0.15 with IR carrier signal
- ◆ RAM size: 2K\*16 bits
- ◆ High performance program ROM: 32K\*16 bits
- ◆ Data ROM size: 224K\*16 bits
- ◆ Total ROM size: 256K\*16 bits
- ◆ Maximum program size: 64K word
- ◆ 8 Interrupt Sources
  - 4 for Internal Timer (timer0, 1, 2 and RTC)
  - 4 for External (P0.0~P0.3)
- ◆ Two voice/melody channels
- ◆ Three 8-bit timer with auto-reload function
- ◆ Built in a 10-bit PWM Direct Drive circuit and a fixed current D/A output
- ◆ Sampling Rate: 8KHz ~16KHz
- ◆ Built-in software voice synthesizer (multiple bit-rate solution 2Kbps, 2.8Kbps, 3.6Kbps, 8Kbps, 10Kbps, 12Kbps, 14Kbps, 16Kbps, 20Kbps, 24Kbps, and 29Kbps @8K, 10K, 12K, 14K, 16K sampling rate)
- ◆ Built-in software melody synthesizer includes the dual-tone melody and 4-ch wave-table melody.
- ◆ Low Voltage Reset



### 3. PIN ASSIGNMENT

Symbol	I/O	Descriptions
P0.0 ~ P0.15	I/O	I/O port 0
P1.0 ~ P1.7	I	Input port 1
CVDD	I	Positive power supply for core circuit
VDD	I	Positive power supply
GND	I	Negative power supply
BP0	O	PWM output 1
BN0	O	PWM output 2
VO	O	DA output
XIN	I	High speed clock crystal input / RC-type oscillator input
XOUT	O	High speed clock crystal output / RC-type oscillator input
LXIN	I	Low speed clock crystal input
LXOUT	O	Low speed clock crystal output
CKSEL	I	Crystal/RC-type oscillator select for high speed clock
RST	I	Chip reset
TEST	I	For test only



#### 4. ROM TABLE

The total ROM size is 256K words. But only 64K words ROM for programming. And 32K words of all is the high speed program ROM. The high-low speed ratio is 1:16, that is to say, if the instruction cycle is two clocks at high speed ROM, the instruction cycle will down to 32 clocks at low speed ROM.

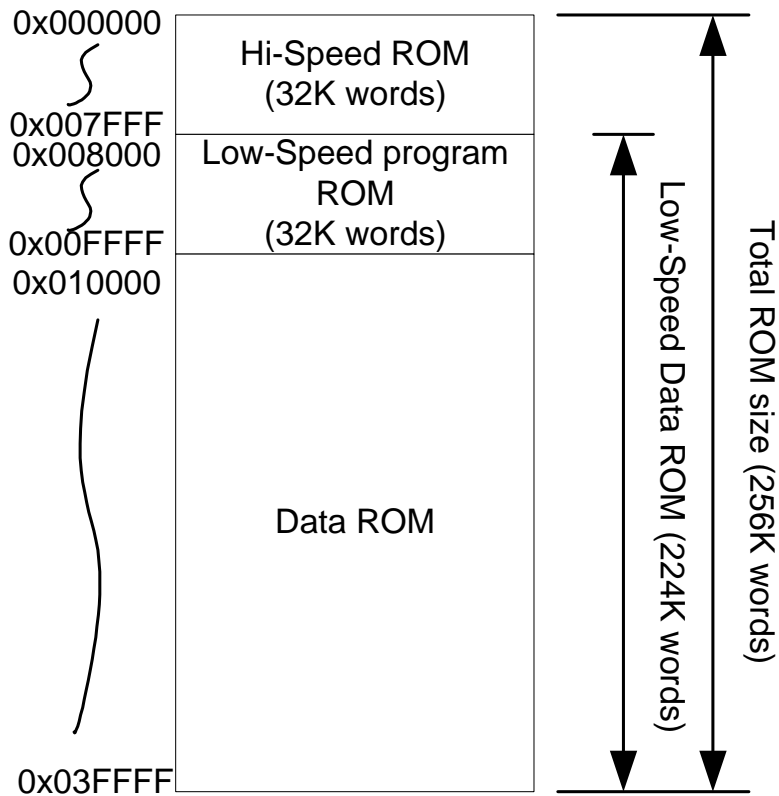

## 5. RAM TABLE

Total RAM size is 2K words, and one bank is 512 words. If user need playing voice (2Kbps, 3.6Kbps, 12Kbps, dual-tone melody and 4-ch wave-table melody), the system will reserve 1.5K words RAM size.

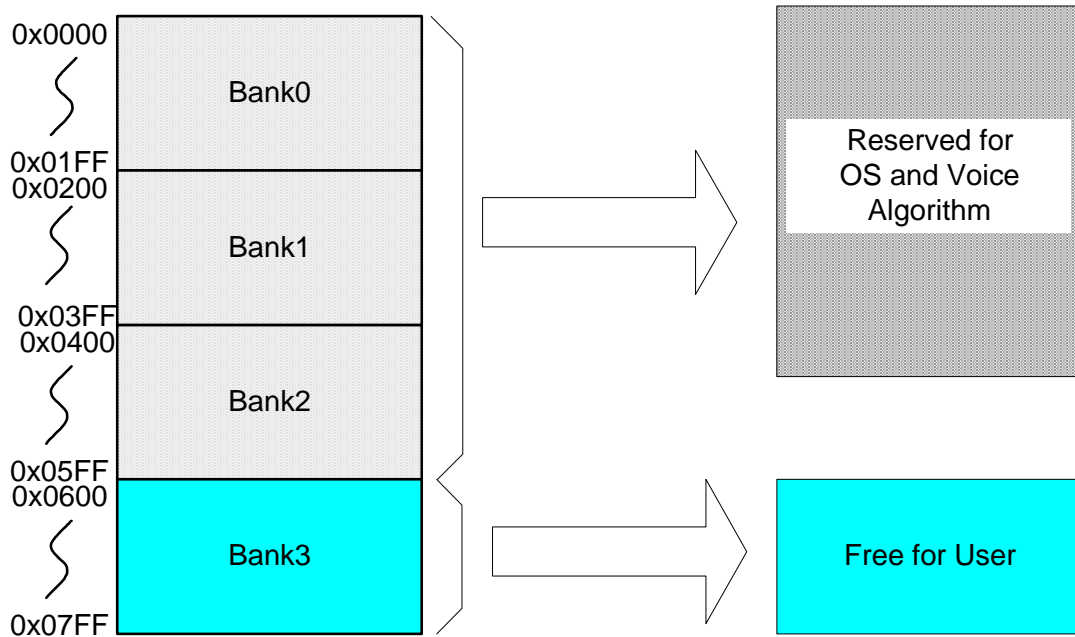

## 6. System Clock

The system clock source also can be selected from 16Mhz crystal or ROSC. For the ROSC, user should connect two resistors in the pin “XIN” and “XOUT” instead of 16MHZ crystal. Beside, the clock source select pin “CKSEL” also should be connected to VDD for ROSC. ***In order to get an accurate system clock by ROSC, the real time clock source is recommended to connect a 32768HZ crystal for system clock calibration.***

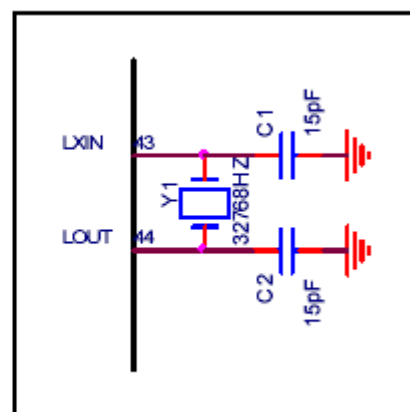
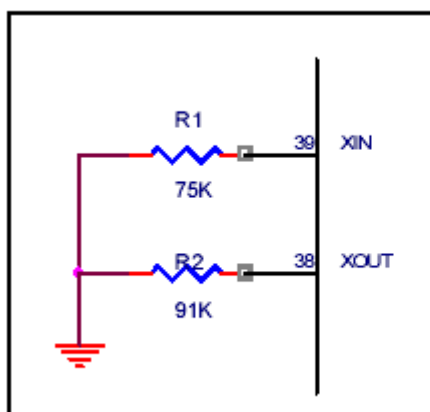

## 7. I/O PORT

SNC735 provides one a 16-bit I/O port and an 8-bit input port for user application (P0.0~P0.15, P1.0~P1.7). The input pull high resistor of each pin can be programmed by Port Pull-High register. The direction of I/O port is selected by Port Direction register. The Port0 (P0.0~P0.15) and Port1 (P1.0~P1.7) can wake the chip up from the stop mode and watch mode. P0.15 can be modulated with a 38.5Khz carry signal to realize IR signal transmission.

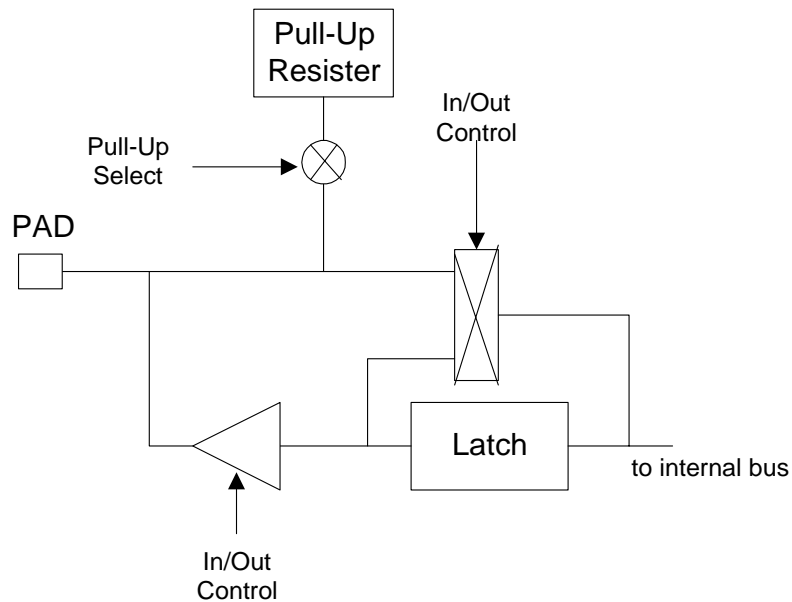

**I/O Configuration of P0.0~P0.15**

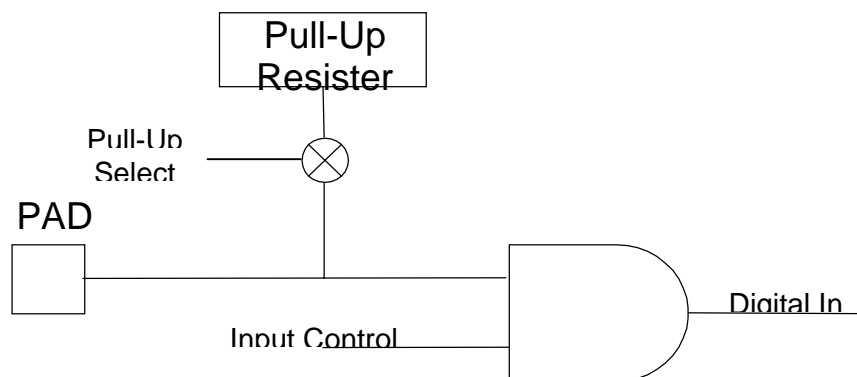

**Input Port Configuration of Port 1 (P1.0~P1.7)**

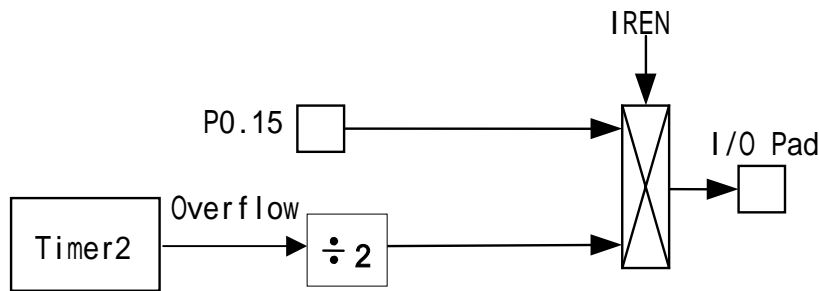

**P0.15 Modulated with a carry signal**

## 8. TIMER/COUNTER

SNC735 provides three 8-bit timer/event counters (T0/T1/T2). Each timer is 8-bit binary up-count timer with pre-scalar and auto-reload function. Timer 0 (T0) is used when voice playing, so user should avoid to use T0.

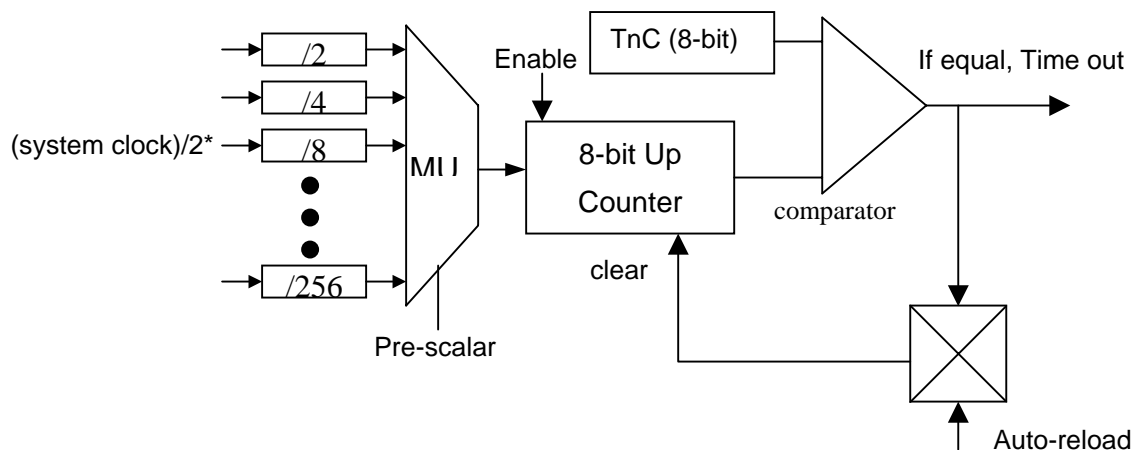

## 9. DAC & PWM

To play out voices, SNC735 contains two different solutions, DAC and PWM, for the users' applications. The user can choose one of these two solutions in his design. Only one function can be activated at one time.

**DAC:** A 10-bit current type digital-to-analog converter is built-in SNC735. The relationship between input digital data and output analog current is listed in the following table. Also, the recommended application circuit is illustrated as follows.

Input data	Typical value of output current (mA)
0	0
1	3/1024
...	
N	$n \cdot (3/1024)$
...	
1024	3

**PWM:** A PWM (pulse width modulation) circuit is built-in SNC735. PWM can convert input digital data into pulse trains with suitable different pulse width. The maximum resolution of PWM is 10 bits. Two huge output stage circuits are included in SNC735. Both of them are capable of driving speaker directly. The recommended application circuit is as follows.

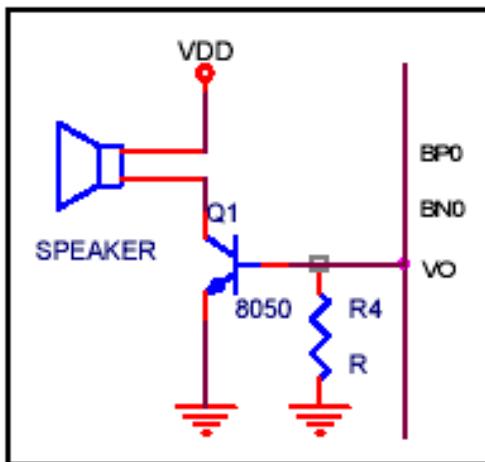

DAC output

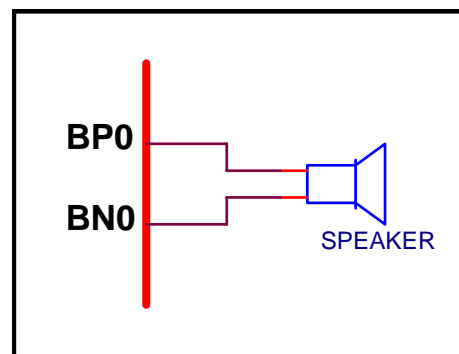

PWM output



## 10. ABSOLUTE MAXIMUM RATINGS

Items	Symbol	Min	Max	Unit.
Supply Voltage	$V_{DD-V}$	-0.3	6.0	V
Input Voltage	$V_{IN}$	GND-0.3	$V_{DD}+0.3$	V
Operating Temperature	$T_{OP}$	-20.0	70.0	°C
Storage Temperature	$T_{STG}$	-55.0	125.0	°C

## 11. ELECTRICAL CHARACTERISTICS

Item	Sym.	Min.	Typ.	Max.	Unit	Condition
Operating Voltage	$V_{DD}$	2.4	-	3.6	V	*1.
	$V_{DD}$	3.6	-	5.1	V	*2.
Standby current	$I_{SBY}$	-	-	2.0	$\mu A$	$V_{DD}=3V$ , no load
Operating Current	$I_{OPR}$	-	-	5	mA	$V_{DD}=3V$ , no load
Input current of P0, P1	$I_{IH}$	-	-	10.0	$\mu A$	$V_{DD}=3V, V_{IN}=3V$
Drive current of P0	$I_{OD}$	6	10	-	mA	$V_{DD}=3V, V_O=2.4V$
Sink Current of P0	$I_{OS}$	8	12	-	mA	$V_{DD}=3V, V_O=0.4V$
Drive current of Buo1	$I_{OD}$	100	120	-	mA	$V_{DD}=3V, Buo1=1.5V$
Sink Current of Buo1	$I_{OS}$	100	120	-	mA	$V_{DD}=3V, Buo1=1.5V$
Drive Current of Buo2	$I_{OD}$	100	120	-	mA	$V_{DD}=3V, Buo2=1.5V$
Sink Current of Buo2	$I_{OS}$	100	120	-	mA	$V_{DD}=3V, Buo2=1.5V$
Oscillation Freq. (crystal)	$F_{OSC}$	-	16.0	-	MHz	$V_{DD}=3V$

Note:

1. For 2 battery application.
2. For 3 battery application, user should add 1 resistor between power and CVDD pin of chip.





**The relationship between ROSC and voltage (Typical)**

T<sub>a</sub> = 25 °C

Frequency unit: MHz

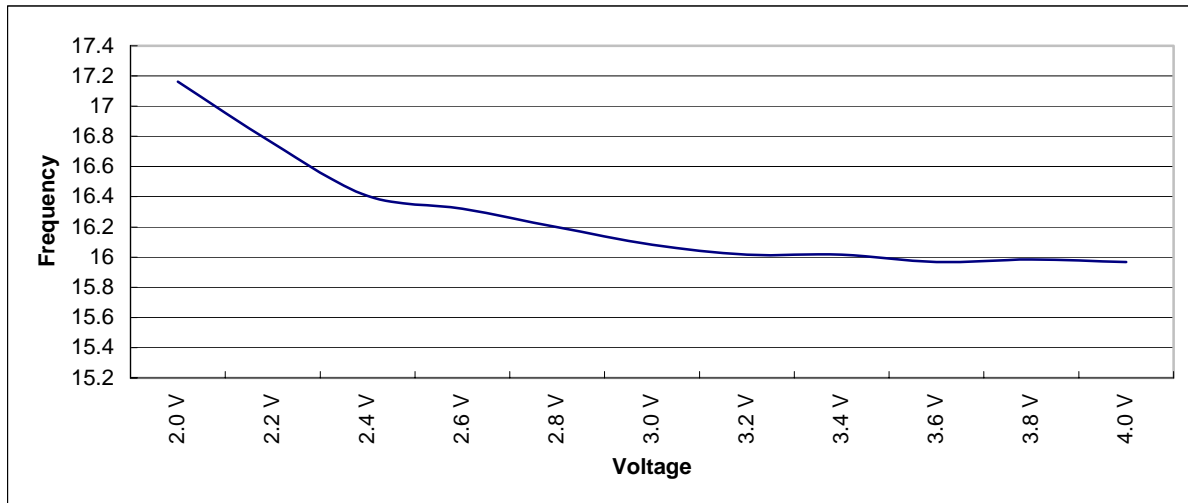

**The relationship between Frequency and Resister (R2) for ROSC (Typical)**

T<sub>a</sub> = 25 °C, R<sub>1</sub> = 75KΩ

Frequency unit: MHz

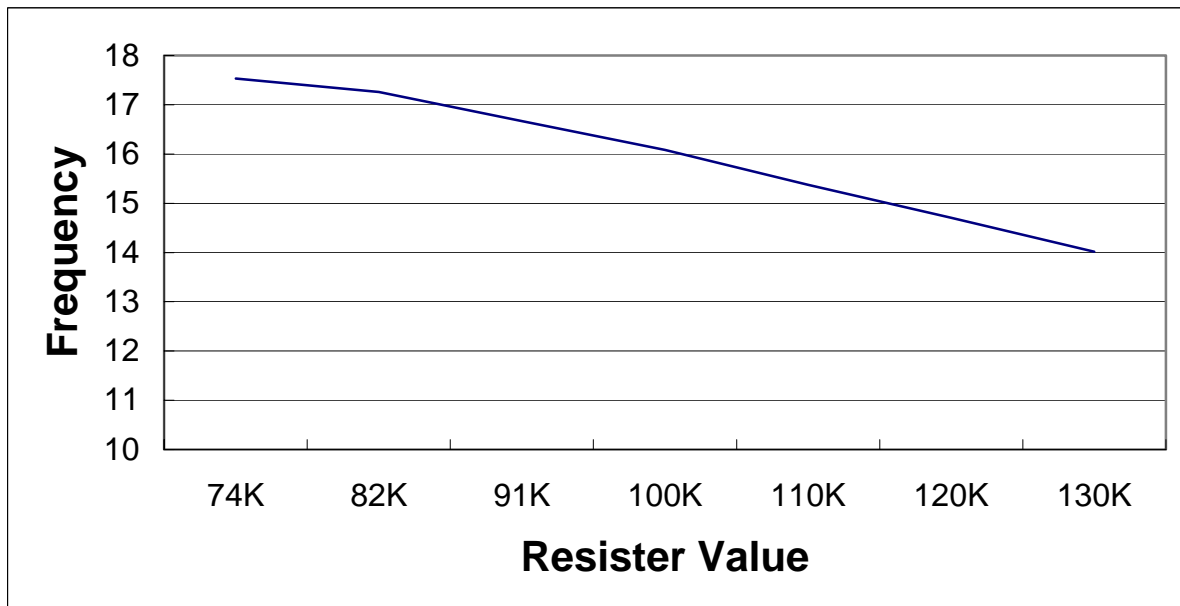

**The relationship between operating current and voltage (Typical)**

T<sub>a</sub> = 25 °C

Current unit: mA

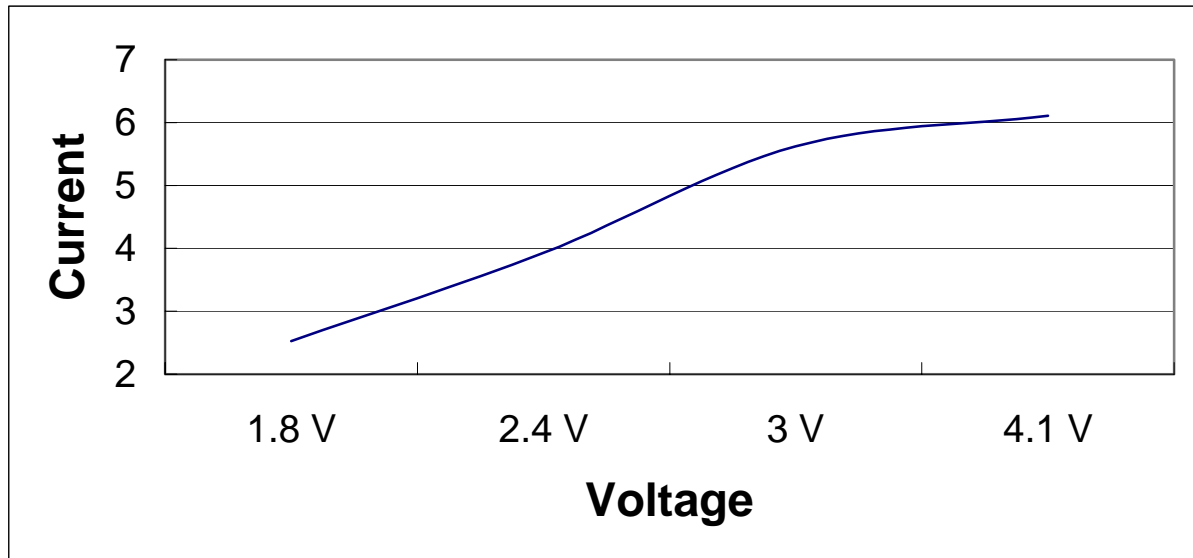



## 12. APPLICATION CIRCUIT

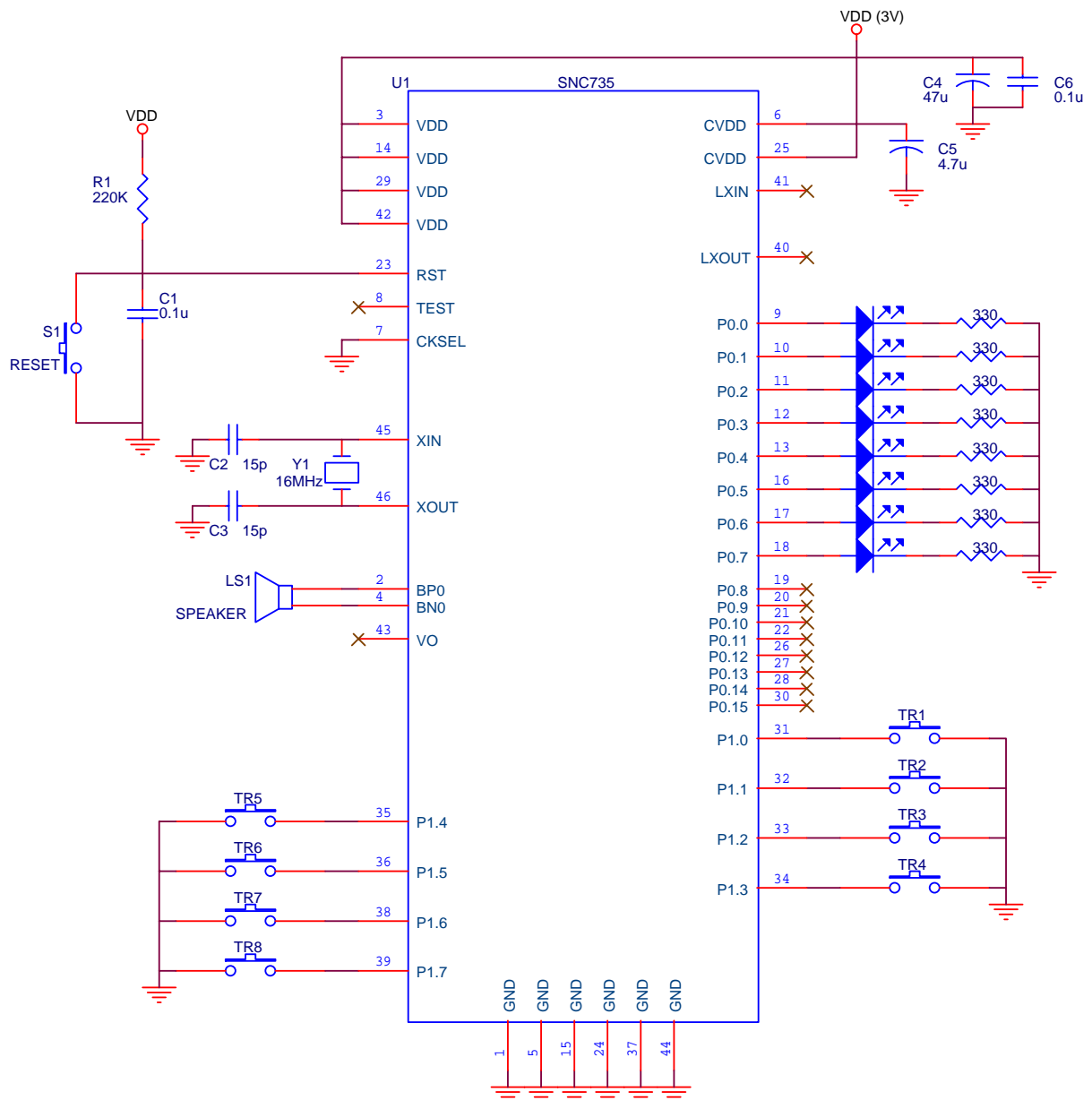

**3V, 16MHz Crystal, PWM**

Note:

1. All the "VDD" and "CVDD" should be connected together before connected to the power source which with a 47uF(C4) capacitor.
2. The capacitor "C5" is near the "CVDD" pin.

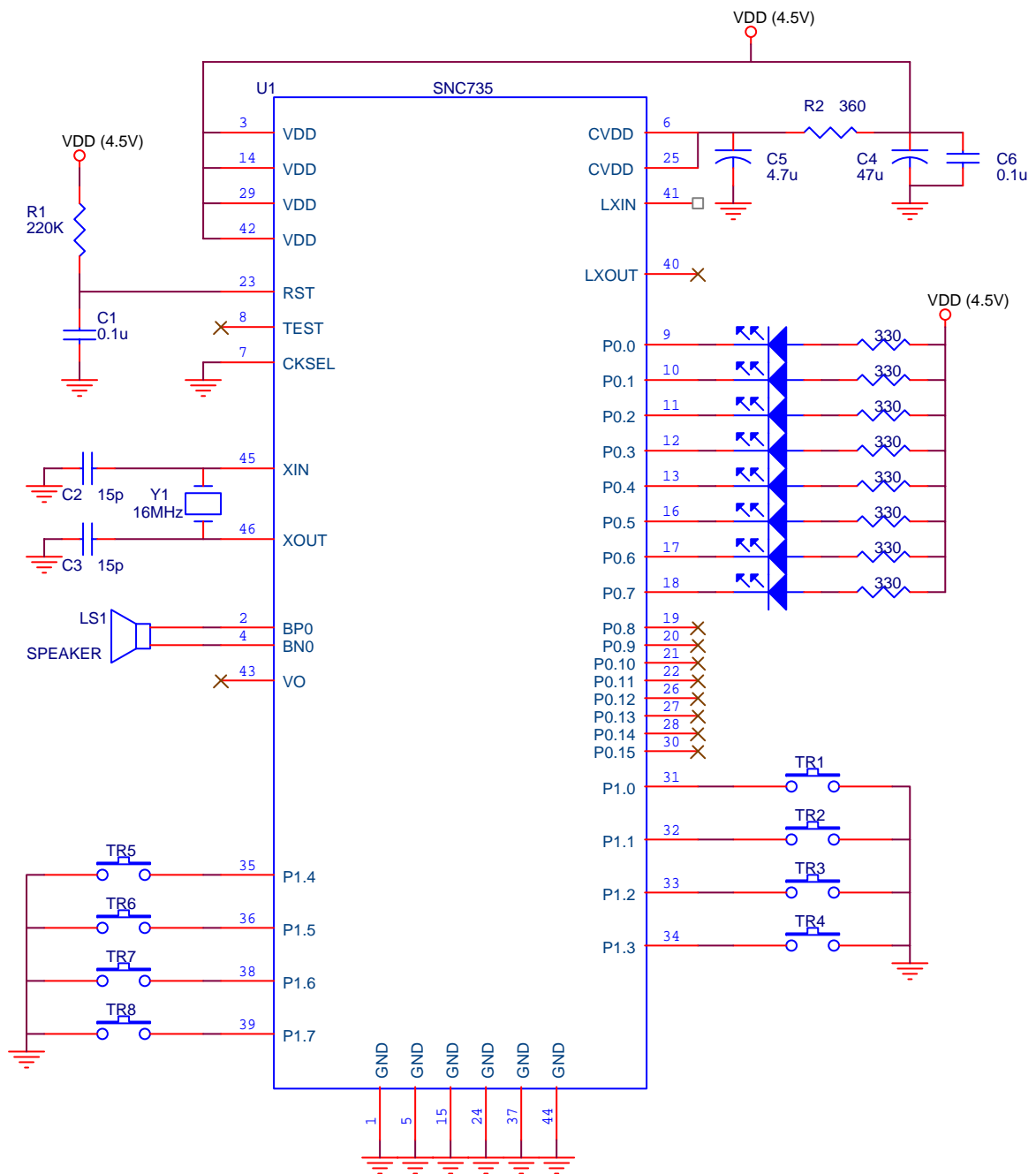

**4.5V, 16MHz Crystal, PWM**

**Note:**

1. All the "VDD" should be connected together before connected to the power source which with a 47uF(C4) capacitor.
2. The capacitor "C5" is near the "CVDD" pin.

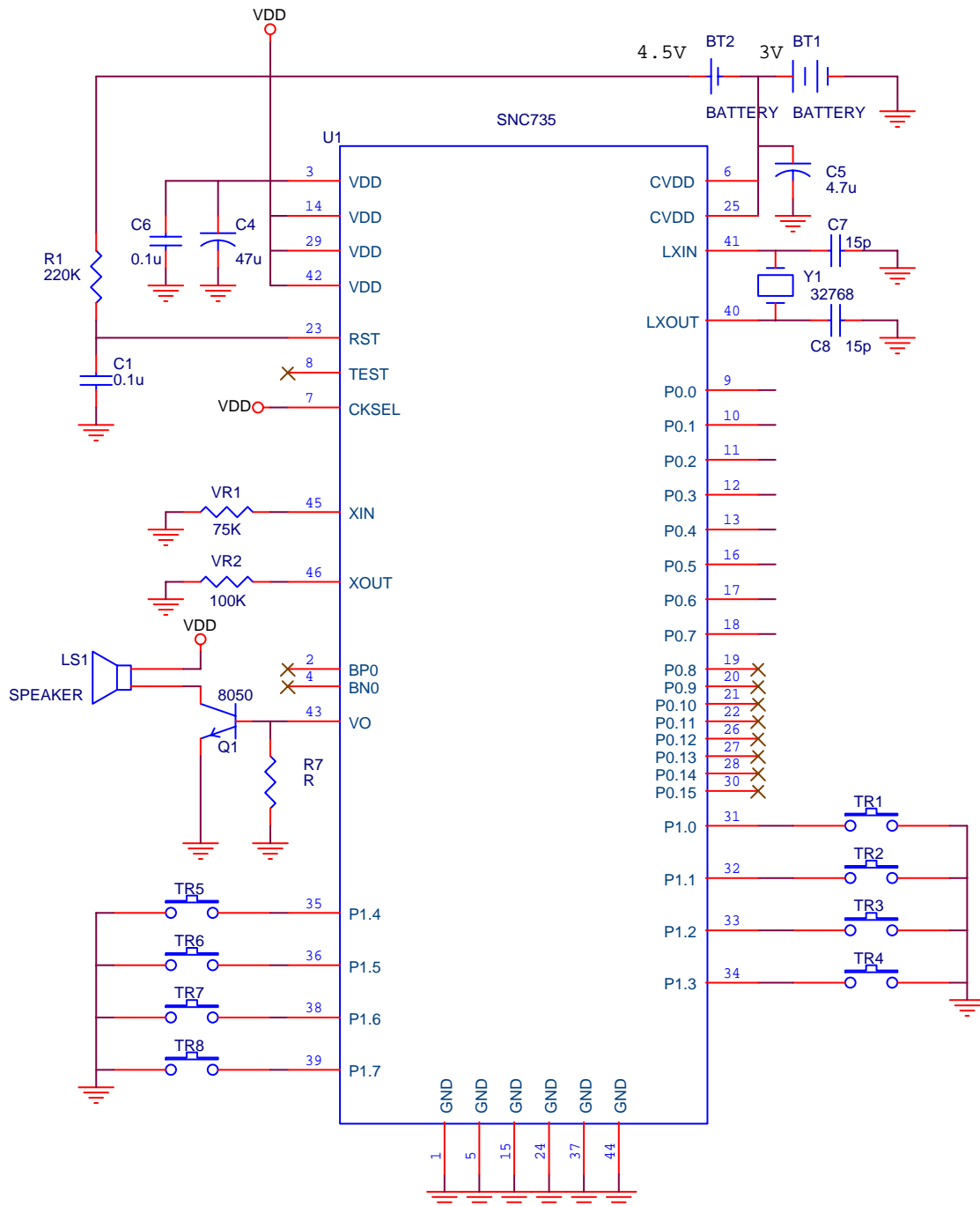

**I/O and VDD 4.5V, CVDD 3V, 16MHz ROSC, DA output**

Note:

1. All the "VDD" should be connected together before connected to the power source which with a 47uF(C4) capacitor.
2. The capacitor "C5" is near the "CVDD" pin.



### 13. BONDING PAD

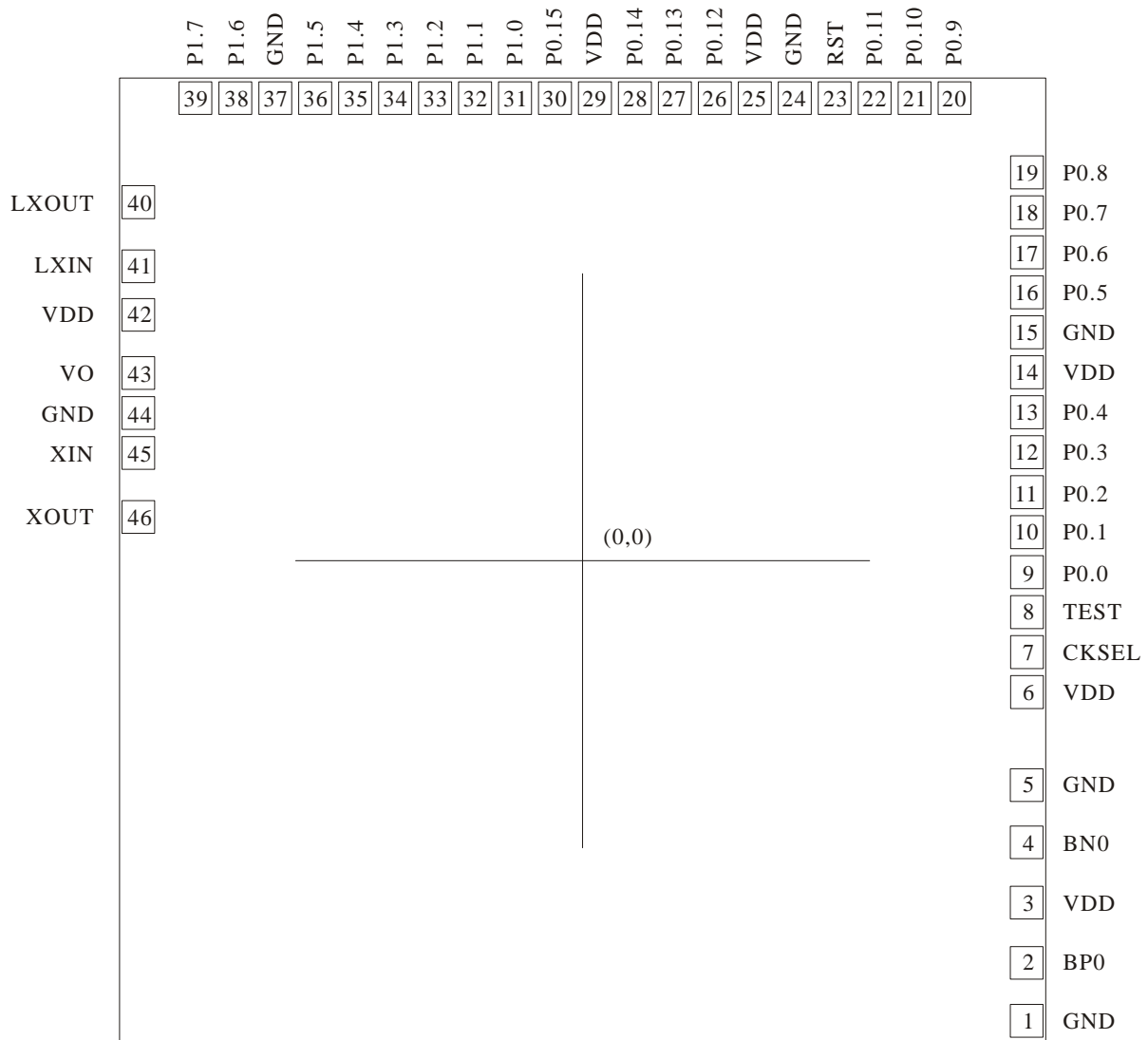

Note: The substrate MUST be connected to Vss in PCB layout.

## **DISCLAIMER**

The information appearing in SONiX web pages (“this publication”) is believed to be accurate.

However, this publication could contain technical inaccuracies or typographical errors. The reader should not assume that this publication is error-free or that it will be suitable for any particular purpose. SONiX makes no warranty, express, statutory implied or by description in this publication or other documents which are referenced by or linked to this publication. In no event shall SONiX be liable for any special, incidental, indirect or consequential damages of any kind, or any damages whatsoever, including, without limitation, those resulting from loss of use, data or profits, whether or not advised of the possibility of damage, and on any theory of liability, arising out of or in connection with the use or performance of this publication or other documents which are referenced by or linked to this publication.

This publication was developed for products offered in Taiwan. SONiX may not offer the products discussed in this document in other countries. Information is subject to change without notice. Please contact SONiX or its local representative for information on offerings available. Integrated circuits sold by SONiX are covered by the warranty and patent indemnification provisions stipulated in the terms of sale only. The application circuits illustrated in this document are for reference purposes only. SONiX DISCLAIMS ALL WARRANTIES, INCLUDING THE WARRANTY OF MERCHANTABILITY OR FITNESS FOR ANY PURPOSE. SONiX reserves the right to halt production or alter the specifications and prices, and discontinue marketing the Products listed at any time without notice. Accordingly, the reader is cautioned to verify that the data sheets and other information in this publication are current before placing orders.

Products described herein are intended for use in normal commercial applications. Applications involving unusual environmental or reliability requirements, e.g. military equipment or medical life support equipment, are specifically not recommended without additional processing by SONiX for such application.