



**===== Contents =====**

<b>1. INTRODUCTION.....</b>	<b>3</b>
<b>2. FEATURES .....</b>	<b>3</b>
<b>3. PIN ASSIGNMENTS.....</b>	<b>4</b>
<b>4. SYSTEM DESCRIPTIONS .....</b>	<b>5</b>
4.1 CONNECTION.....	5
4.2 MEMORY MAPPING .....	6
4.3 SYSTEM CLOCK.....	6
4.4 I/O PORT .....	7
4.5 TIMER/COUNTER.....	8
4.6 DAC & PWM.....	8
<b>5. ABSOLUTE MAXIMUM RATINGS .....</b>	<b>10</b>
<b>6. ELECTRICAL CHARACTERISTICS .....</b>	<b>10</b>
<b>7. APPLICATION CIRCUIT .....</b>	<b>11</b>
7.1 3V/16M CRYSTAL .....	11
7.2 3V/16M ROSC.....	12
7.3 4.5V/16M CRYSTAL .....	13
7.4 4.5V/16M ROSC.....	14
<b>8. BONDING PAD .....</b>	<b>15</b>



**AMENDENT HISTORY**

<b>Version</b>	<b>Date</b>	<b>Description</b>
Ver 1.1	December 3, 2002	V1.1 first issue
Ver 1.2	March 20, 2003	Add application circuit
Ver 1.3	April 2, 2003	Page4, 15: Wording modification Update application circuit
Ver 1.4	July 30, 2003	Page5: Wording modification (and SNC710 allows user to connect totally <b>2</b> external mask ROMs)
Ver 1.5	October 18 , 2007	Update Bounding Pad (The Ver 1.5 bounding pad is corrected to real chip IC pad location define)

## 1. INTRODUCTION

The SNC710 is a powerful voice engine, which is based on 16-bit fixed-point DSP architecture. This chip embedded 32K words hi-performance ROM and 2K words RAM. This internal ROM is used to implement software synthesizer in order to provide various flexible sound effects for users, such as 2kbps~24kbps voice compression, 4-CH wave-table melody etc.... Furthermore, the SNC710 also built-in a SONiX's mask ROM interface, all the user's program and voice data should be stored in external mask ROM. And SNC710 can execute user's program from this external mask ROM.

## 2. FEATURES

- ◆ Power supply: 2.4V ~ 3.6V (for 2 battery application)  
3.6V ~ 5.1V (for 3 battery application)
- ◆ Built-in a 16-bit DSP (Very Light Structure)
- ◆ Software-based voice/melody processing
- ◆ Rich Function Instruction Set
- ◆ 16MHz crystal or R-C type oscillator for system clock
- ◆ 8 MIPS CPU performance
- ◆ I/O Ports:
  - 16 I/O pins (P0.0~P0.15) and 8 input pins (P1.0~P1.7)
  - P0.15 with IR carrier signal
- ◆ RAM size: 2K\*16 bits
- ◆ High performance program ROM: 32K\*16
- ◆ Watch-Mode for real time clock (32768HZ clock source)
- ◆ 9 Interrupt Sources
  - 4 for Internal Timer (timer0, 1, 2 and RTC)
  - 4 for External interrupt(P0.0~P0.3)
  - 1 for DA or PWM
- ◆ Three 8-bit timer with auto-reload function
- ◆ Built in a 10-bit PWM Direct Drive circuit and a fixed current D/A output
- ◆ Sampling Rate: 4KHz ~16KHz
- ◆ Built-in software voice synthesizer (multiple bit-rate solution from 2Kbps ~ 24Kbps @8K sampling rate)
- ◆ Low Voltage Reset



### 3. PIN ASSIGNMENTS

Symbol	I/O	Function Description
P0.0~P0.15	I/O	I/O Port 0
P1.0~P1.7	I	Input Port 1
VDD	I	Positive power supply for digital I/O pad
GND	I	Negative power supply for digital I/O pad & core
CVDD	I	Positive power supply for DSP core & AD bus interface
BP0	O	PWM output 1
BN0	O	PWM output 2
VO0	O	DA0 converter output
XIN/VR1	I	High clock crystal input /RC oscillator input
XOUT/VR2	I/O	High clock crystal output/RC oscillator input
LXIN	I	Low clock oscillator input
LXOUT	O	Low clock oscillator output
CKSEL	I	Crystal/RC oscillator system clock select
ALECLK	O	System Clock output
CEB	O	External ROM Enable , active low
READY	I/O	Data Ready(I)/ Reset(O)
CLKIN	I	Bus system clock in
CEIN	I	External ROM enable in
AD[0..7]	I/O	ROM Address/Data Bus (AD Bus)
RST	I	Chip reset (active low)
TestM	I	TEST pin
EXTM	I	External ROM Share Mode

## 4. SYSTEM DESCRIPTIONS

### 4.1 Connection

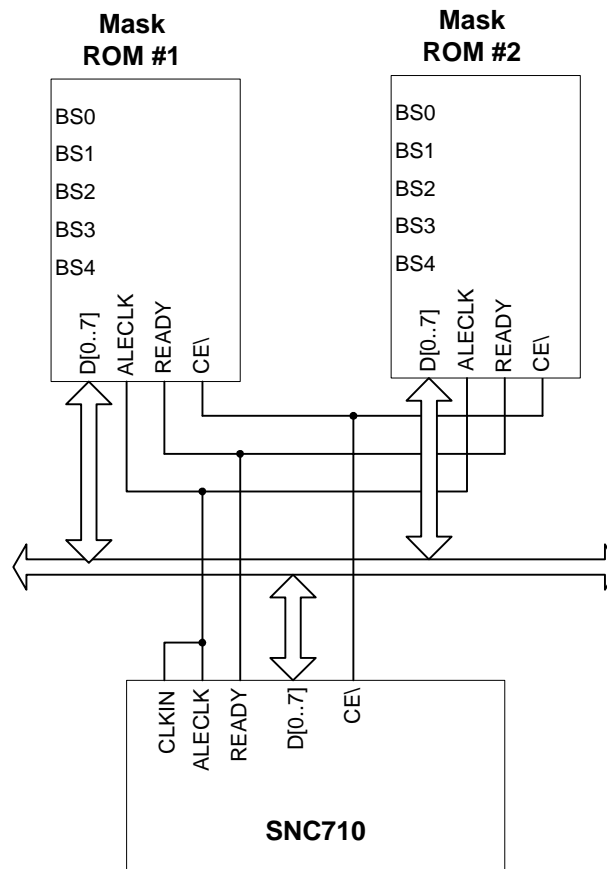

**Figure-1**

The SNC710 is a ROM-less DSP architecture, but it still built-in 32K hi-speed ROM for software voice synthesizer. All the user's program and voice data are stored in external mask ROM that provided by SONiX. In **Figure-1**, show out the system connection between SNC710 and external mask ROM. Each mask ROM both has several bank select pins (BSn) to specify the memory region, and SNC710 allows user to connect totally 2 external mask ROMs.

The SNC710 built-in an 8-bit AD (address/data) bus, which connect to SONiX's mask ROM. And SONiX's mask ROM provides encryption code function to protect user's program to avoid illegal copy. In SONiX's compiler system, user can assign his own ID-Code to protect his program and data.

### 4.2 Memory Mapping

The SNC710 provides totally 24-bit address for mask ROM addressing. The whole ROM area is divided into 8 pages, each page's addressing ability is 32M bits (2M words). The first ROM page is reserved for system. It built-in 32K words high speed ROM internally for Voice decompressed algorithm. The actual addressing capability free for user is 224M bits (14M words). The memory mapping of external mask ROM is shown as bellow:

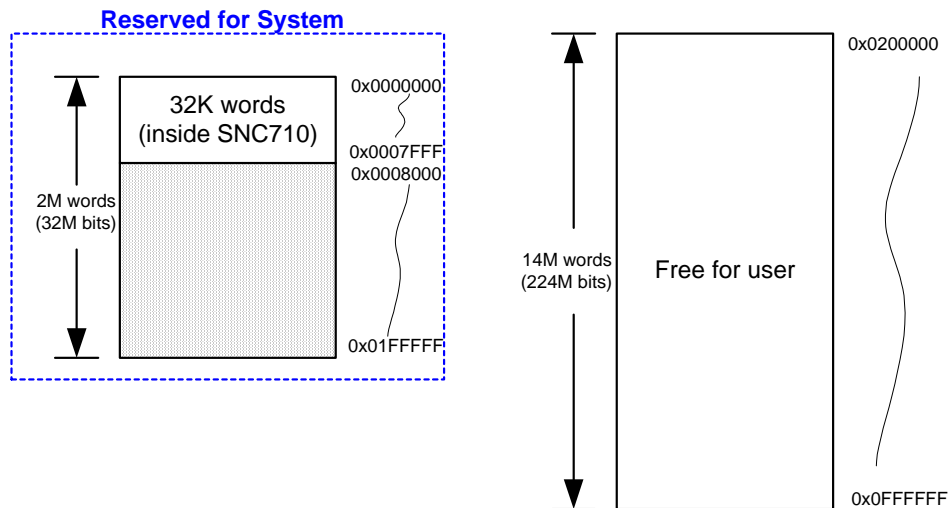

**Table-1**

### 4.3 System Clock

The system clock source also can be selected from 16MHZ Rosc. For the ROSC, user should connect two resistors in the pin “XIN” and “XOUT” instead of 16MHZ crystal. Beside, the clock source select pin “CKSEL” also should be connected to VDD for ROSC. ***In order to get an accurate system clock by ROSC, the real time clock source is recommended to connect a 32768HZ crystal for system clock calibration.***

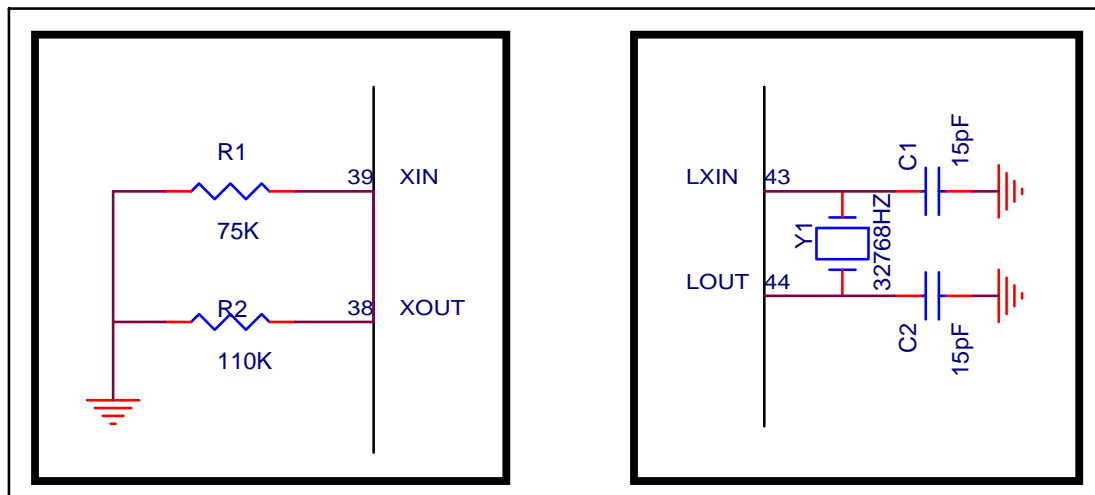

#### 4.4 I/O Port

SNC710 provides one a 16-bit I/O port and an 8-bit input port for user application (P0.0~P0.15, P1.0~P1.7). The input pull high resistor of each pin can be programmed by Port Pull-High register. The direction of I/O port is selected by Port Direction register. The Port0 (P0.0~P0.15) and Port1 (P1.0~P1.7) can wake the chip up from the stop mode and watch mode. And P0.15 Modulated with a carry signal

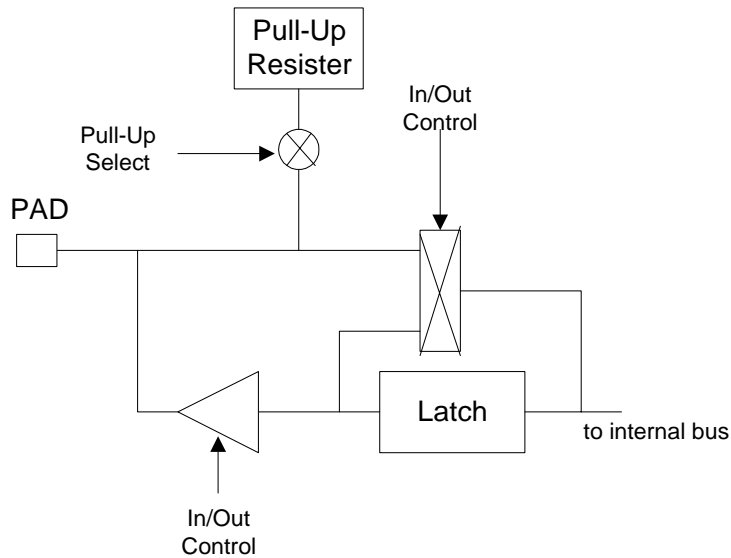

**I/O Configuration of P0.0~P0.15**

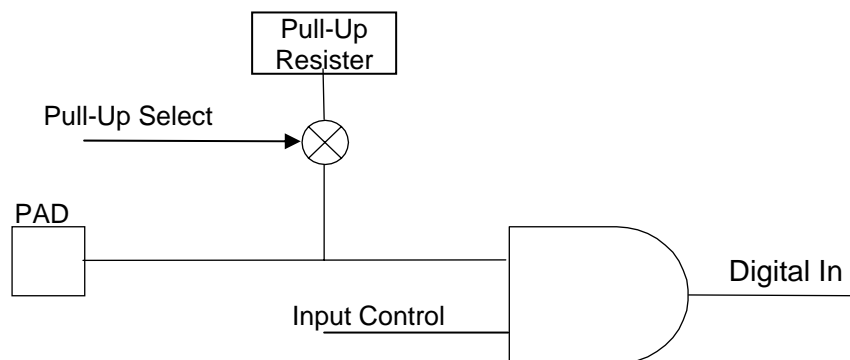

**Input Port Configuration of Port 1 (P1.0~P1.7)**

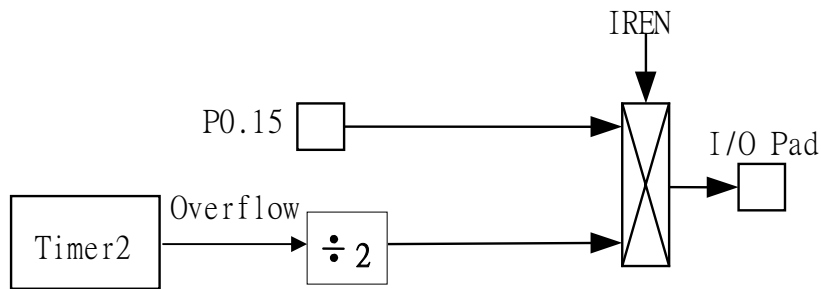

**P0.15 Modulated with a carry signal**

#### 4.5 Timer/Counter

SNC710 provides three 8-bit timer/event counters (T0/T1/T2). Each timer is 8-bit binary up-count timer with pre-scalar and auto-reload function. Timer 0 (T0) is used when voice playing, so user should avoid to use T0.

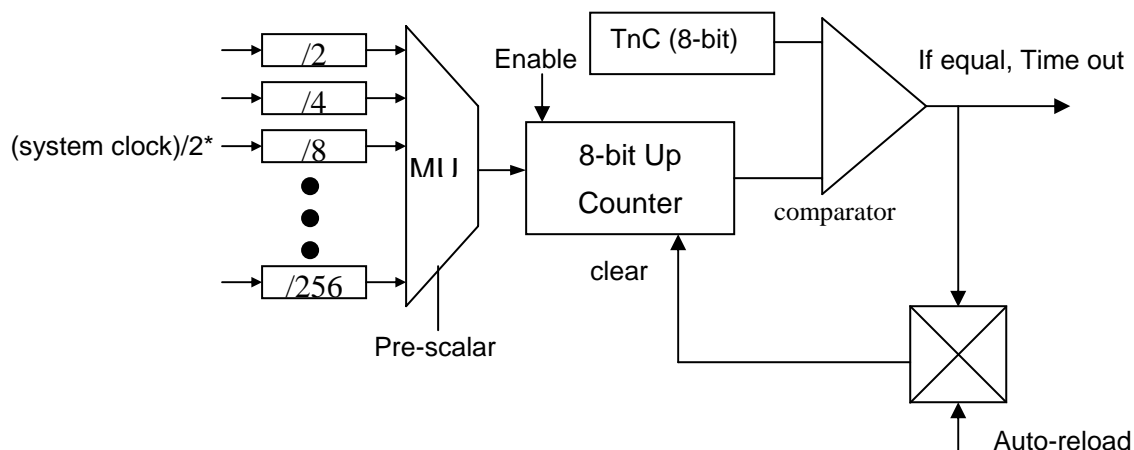

#### 4.6 DAC & PWM

To play out voices, SNC710 contains two different solutions, DAC and PWM, for the users' applications. The user can choose one of these two solutions in his design. Only one function can be activated at one time.

**DAC:** A 10-bit current type digital-to-analog converter is built-in SNC710. The relationship between of input digital data and output analog current signal is listed in the following table. Also, the recommended application circuit is illustrated as follows.



Input data	Typical value of output current (mA)
0	0
1	3/1024
...	
N	$n \cdot (3/1024)$
...	
1024	3

**PWM:** A PWM (pulse width modulation) circuit is built-in SNC710. PWM can convert input digital data into pulse trains with suitable different pulse width. The maximum resolution of PWM is 10 bits. Two huge output stage circuits are included in SNC710. Both of them are capable of driving speaker directly. The recommended application circuit is as follows.

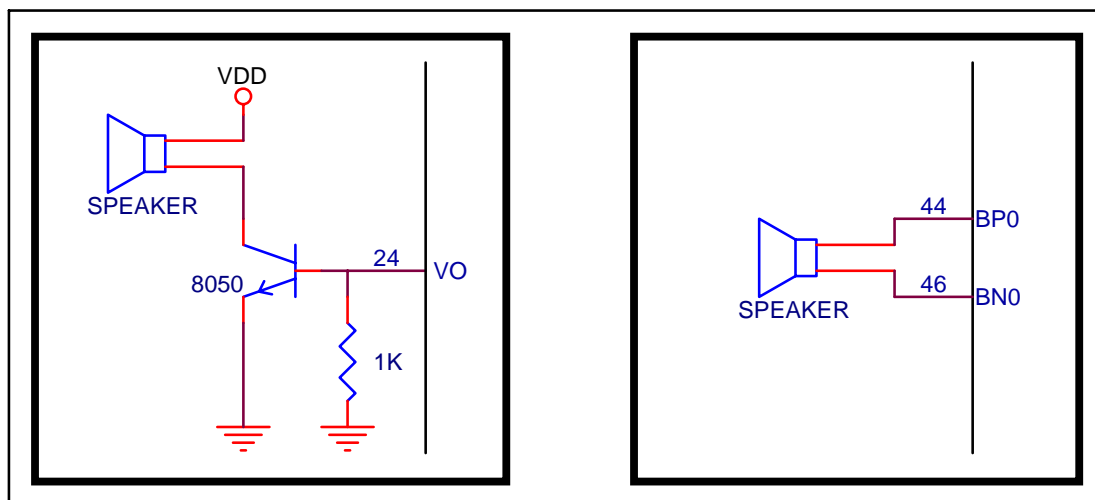

DAC output

PWM output

## 5. ABSOLUTE MAXIMUM RATINGS

Items	Symbol	Min	Max	Unit.
Supply Voltage	$V_{DD-V}$	-0.3	6.0	V
Input Voltage	$V_{IN}$	GND-0.3	$V_{DD}+0.3$	V
Operating Temperature	$T_{OP}$	-20.0	70.0	°C
Storage Temperature	$T_{STG}$	-55.0	125.0	°C

## 6. ELECTRICAL CHARACTERISTICS

Item	Sym.	Min.	Typ.	Max.	Unit	Condition
Operating Voltage	$V_{DD}$	2.4	-	3.6	V	*1.
	$V_{DD}$	3.6	-	5.1	V	*2.
Standby current	$I_{SBY}$	-	-	2.0	$\mu A$	$V_{DD}=3V$ , no load
Operating Current	$I_{OPR}$	-	-	5	mA	$V_{DD}=3V$ , no load
Input current of P0, P1	$I_{IH}$	-	-	10.0	$\mu A$	$V_{DD}=3V, V_{IN}=3V$
Drive current of P0	$I_{OD}$	-	10	-	mA	$V_{DD}=3V, V_O=2.4V$
Sink Current of P0	$I_{OS}$	-	12	-	mA	$V_{DD}=3V, V_O=0.4V$
Drive current of Buo1	$I_{OD}$	100	120	-	mA	$V_{DD}=3V, Buo1=1.5V$
Sink Current of Buo1	$I_{OS}$	100	120	-	mA	$V_{DD}=3V, Buo1=1.5V$
Drive Current of Buo2	$I_{OD}$	100	120	-	mA	$V_{DD}=3V, Buo2=1.5V$
Sink Current of Buo2	$I_{OS}$	100	120	-	mA	$V_{DD}=3V, Buo2=1.5V$
Oscillation Freq. (crystal)	$F_{OSC}$	-	16.0	-	MHz	$V_{DD}=3V$

**Note:**

1. **For 2 batteries application.**
2. **For 3 batteries application, user should add 1 resister between power and CVDD pin of chip.**

## 7. APPLICATION CIRCUIT

### 7.1 3V/16M Crystal

3V power supply with 16M crystal input and PWM output

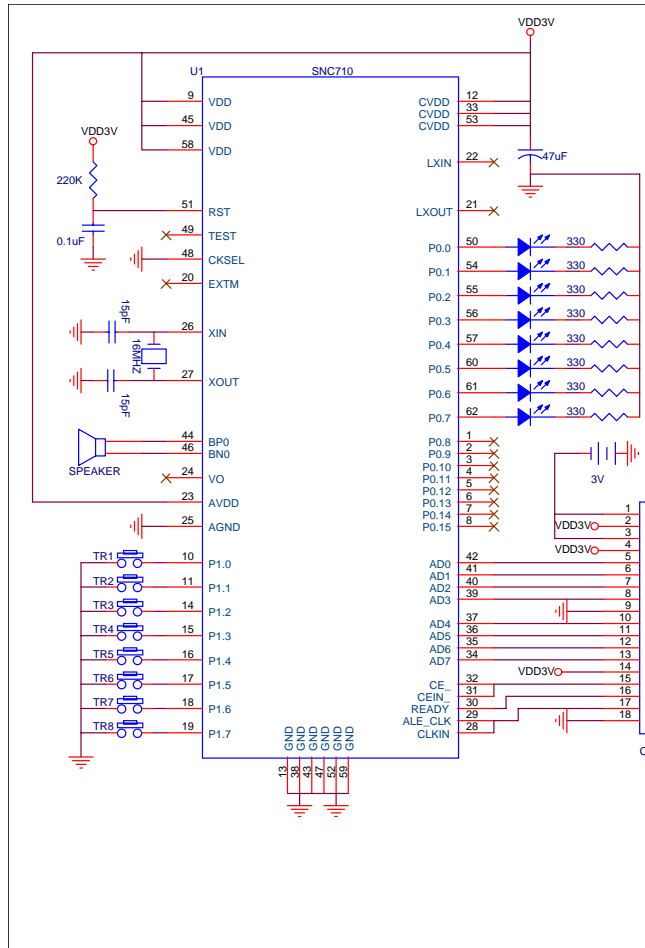

SNC710 Main Board

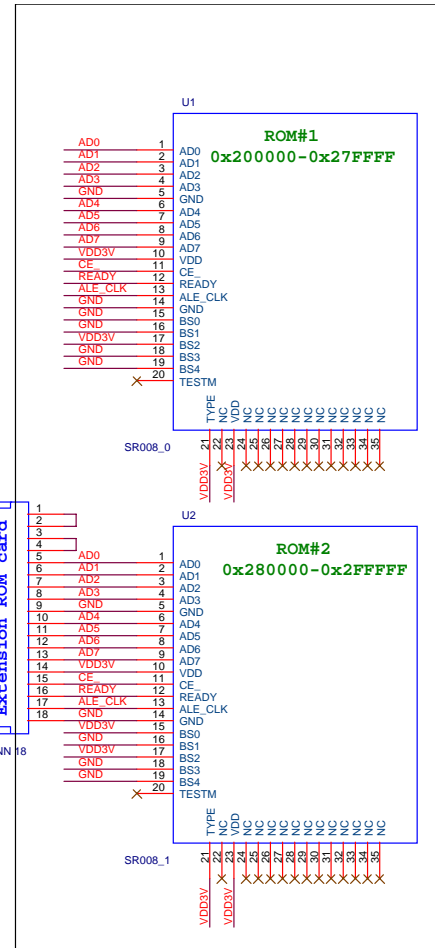

Extension ROM board

## 7.2 3V/16M ROSC

3V power supply with 16Mhz ROSC and PWM output

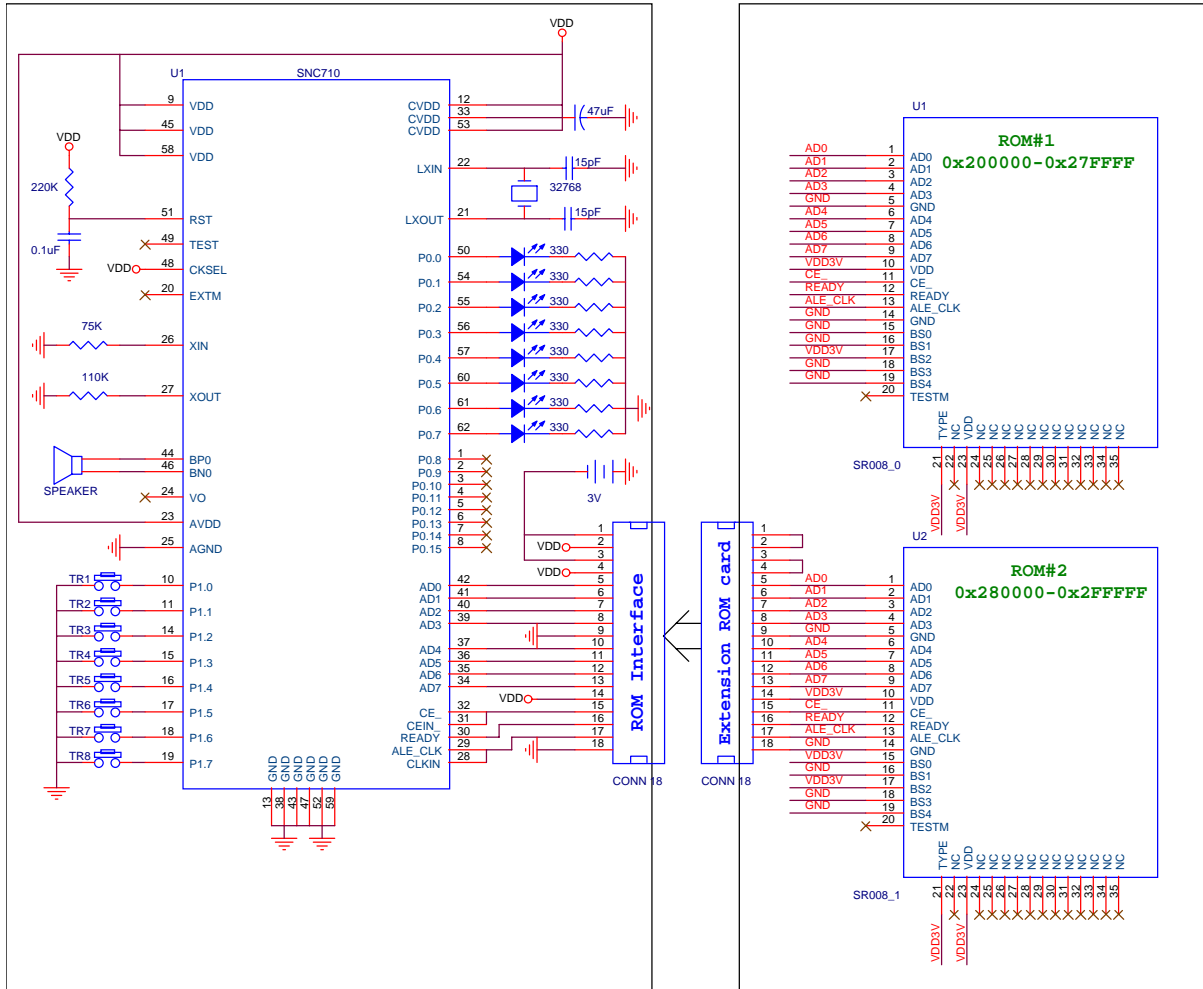

SNC710 Main Board

Extension ROM board

### 7.3 4.5V/16M Crystal

4.5V power supply with 16M crystal input and PWM output

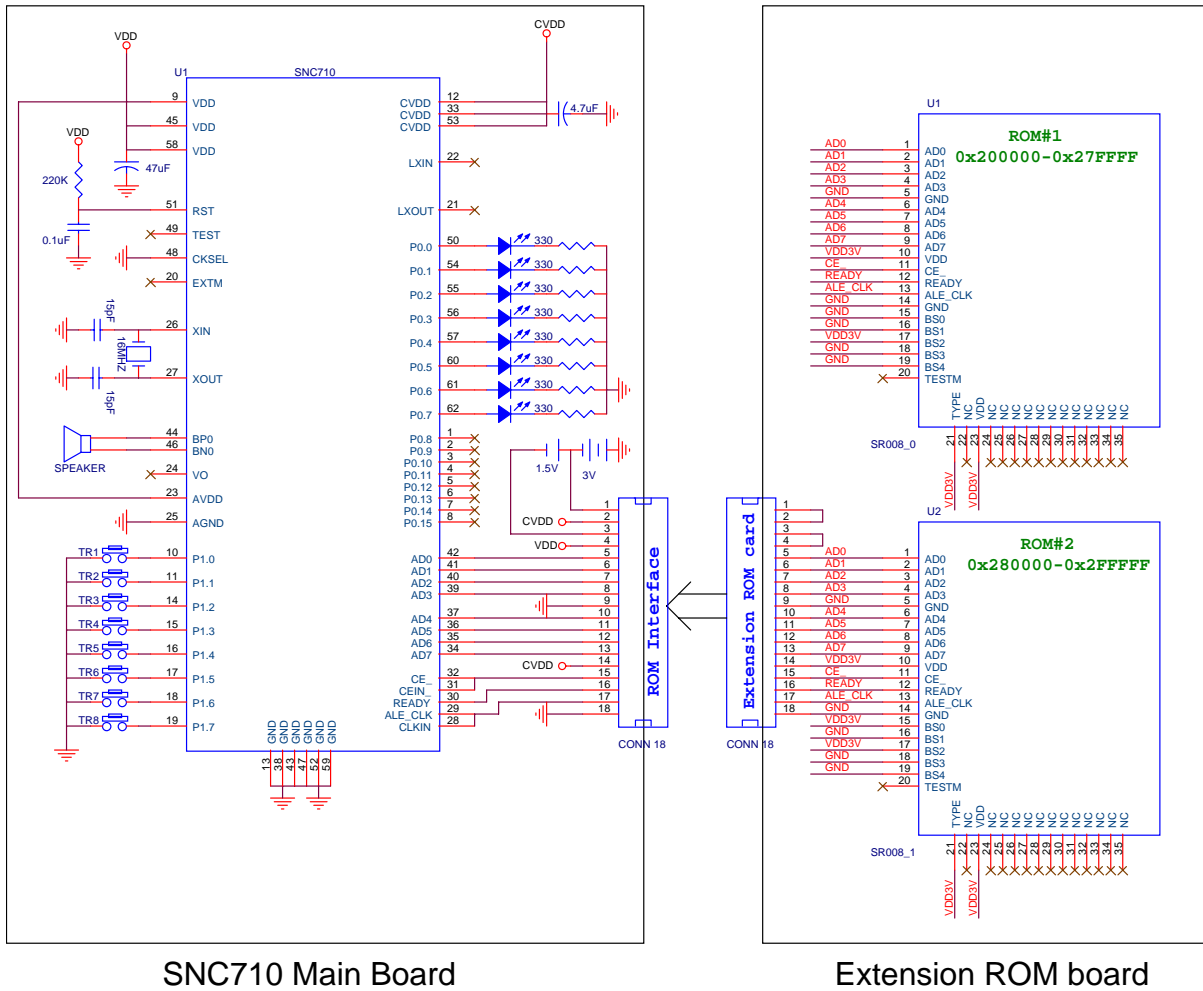

SNC710 Main Board

Extension ROM board

### 7.4 4.5V/16M ROSC

4.5V power supply with 16Mhz ROsc and PWM output

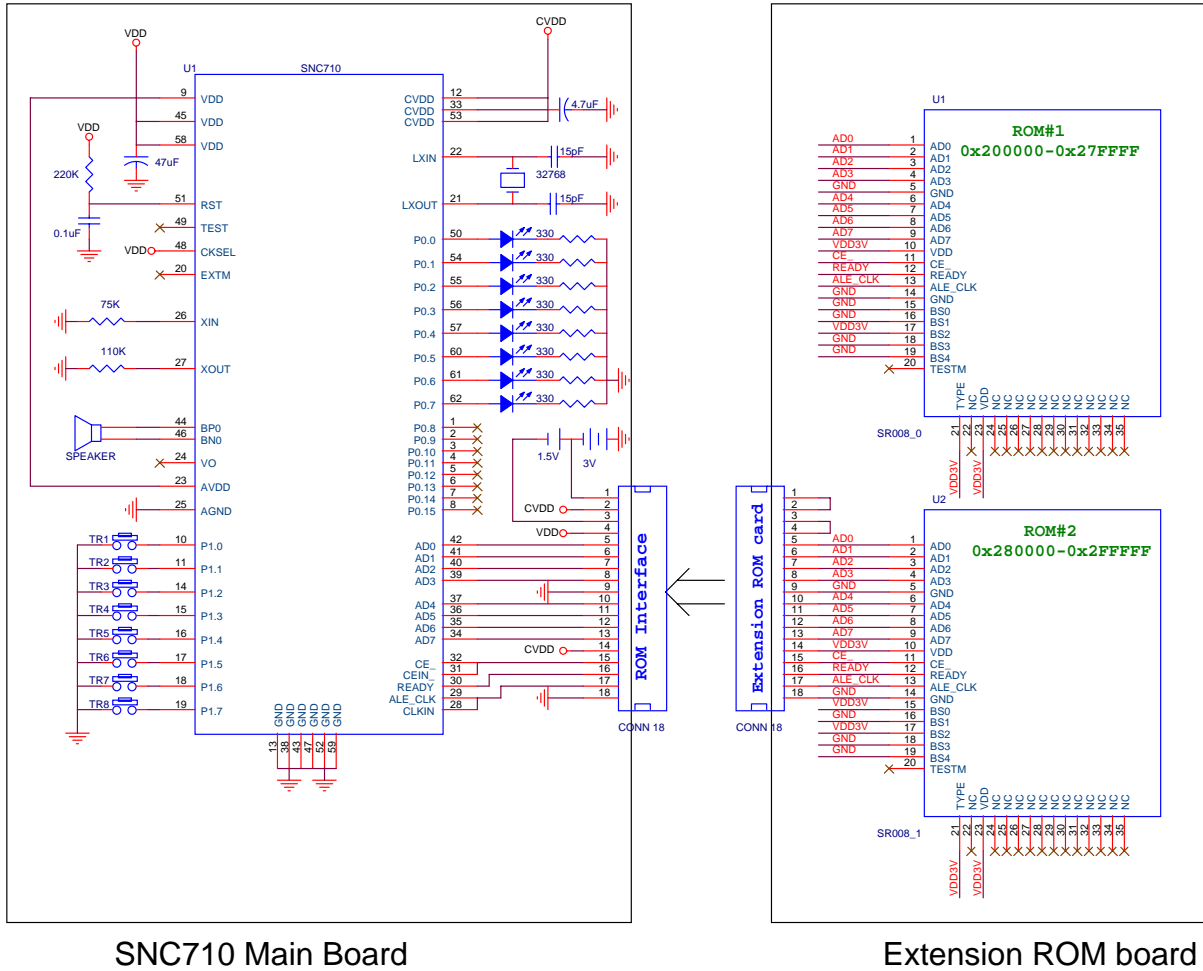

## 8. Bonding Pad

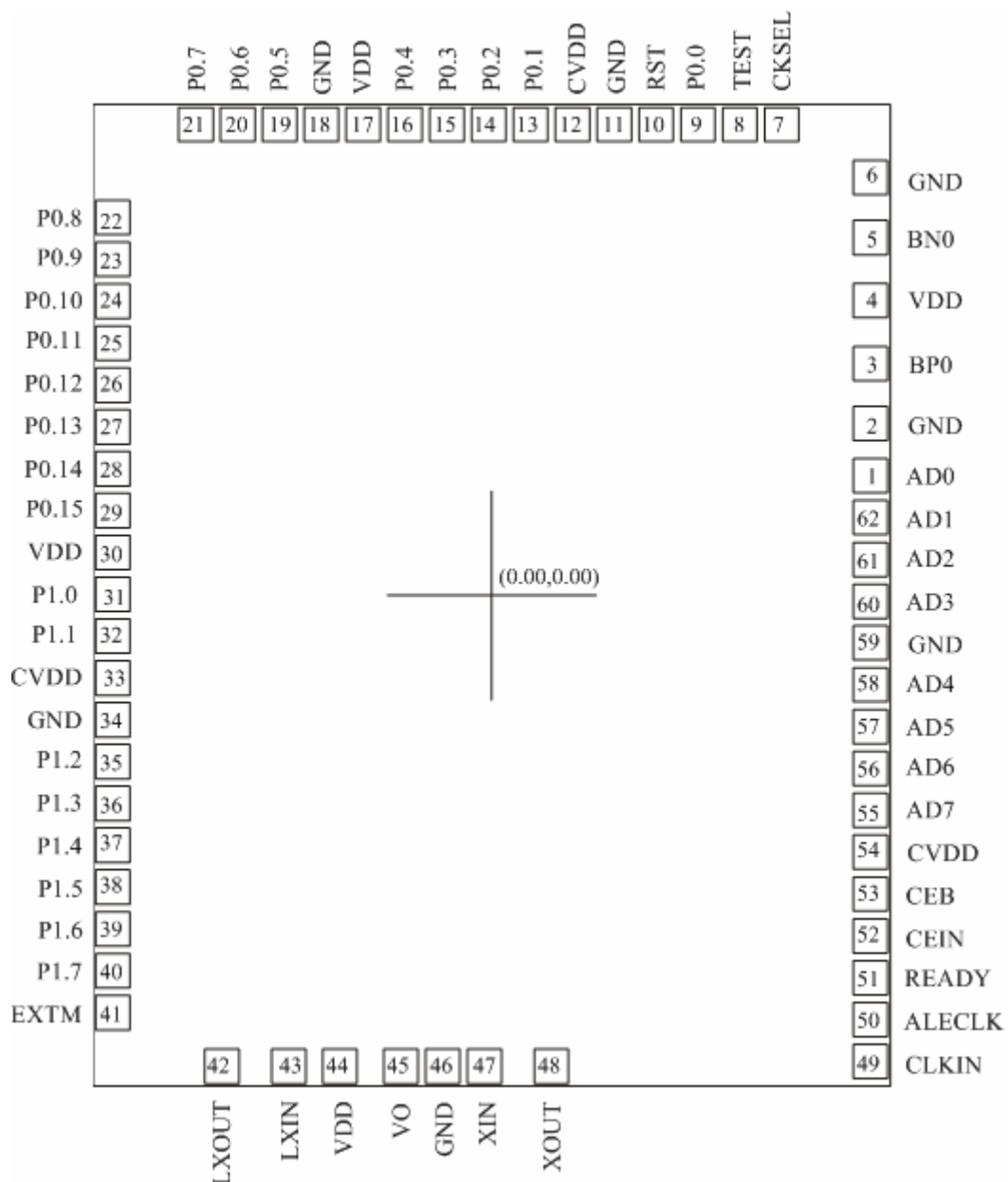

**Note: 1. The substrate MUST be connected to Vss in PCB layout.**

**2. The bounding pad is corrected to snc710 real chip pad location define.**

## DISCLAIMER

The information appearing in SONiX web pages (“this publication”) is believed to be accurate.

However, this publication could contain technical inaccuracies or typographical errors. The reader should not assume that this publication is error-free or that it will be suitable for any particular purpose. SONiX makes no warranty, express, statutory implied or by description in this publication or other documents which are referenced by or linked to this publication. In no event shall SONiX be liable for any special, incidental, indirect or consequential damages of any kind, or any damages whatsoever, including, without limitation, those resulting from loss of use, data or profits, whether or not advised of the possibility of damage, and on any theory of liability, arising out of or in connection with the use or performance of this publication or other documents which are referenced by or linked to this publication.

This publication was developed for products offered in Taiwan. SONiX may not offer the products discussed in this document in other countries. Information is subject to change without notice. Please contact SONiX or its local representative for information on offerings available. Integrated circuits sold by SONiX are covered by the warranty and patent indemnification provisions stipulated in the terms of sale only. The application circuits illustrated in this document are for reference purposes only. SONiX DISCLAIMS ALL WARRANTIES, INCLUDING THE WARRANTY OF MERCHANTABILITY OR FITNESS FOR ANY PURPOSE. SONiX reserves the right to halt production or alter the specifications and prices, and discontinue marketing the Products listed at any time without notice. Accordingly, the reader is cautioned to verify that the data sheets and other information in this publication are current before placing orders.

Products described herein are intended for use in normal commercial applications. Applications involving unusual environmental or reliability requirements, e.g. military equipment or medical life support equipment, are specifically not recommended without additional processing by SONiX for such application.