



佑華微電子股份有限公司

AMSRC SERIES

DATA SHEET

佑華微電子股份有限公司

新竹市光復路二段 295 號 9 樓之 1 號

電話: 03-573 6660

傳真: 03-573 6661

www.ealpha.com.tw

Alpha Microelectronics Corp.

9F-1, 295, Sec. 2, Kuang Fu Rd., Hsinchu, Taiwan

Tel : +886-3-573 6660

Fax: +886-3-573 6661

www.ealpha.com.tw

Revision History

<i>Revision#</i>	<i>Date</i>	<i>Description</i>	<i>Page</i>
1.0	2005/11/3	Original	

1.0 一般規格

AMSRC010A、AMSRC015A、AMSRC020A 是簡單的單晶片錄放音 IC，可藉由不同的震盪頻率來調整錄音時間，能用來儲存一段或兩段錄音信息，且在兩段錄音模式時支援固定時間分段和不固定時間分段。此 IC 已內建了低通濾波器(LPF)來減少錄音時的噪音，並建有 PWM 輸出來直接推動喇叭或蜂鳴片以降低功率消耗。除了有兩個錄音及放音的 LED 指示燈外，它還提供一個特殊的留言指示燈功能。此 IC 非常適合用於攜帶式的錄音設備、玩具和其他消費性的產品。

2.0 特性

- (1) 單一工作電壓範圍: 2.4 ~ 5.5 伏特。(在此範圍內，可採用單一 R_{osc} 電阻值)
- (2) 震盪模式: R oscillator.
- (3) 低靜態電流, <1uA@3V.
- (4) 內建SRAM記憶體以供錄音，可經由調整震盪電阻來選擇不同的取樣頻率以獲得不同的錄音時間。

	4.0KHz	5.0KHz	5.3KHz	6.0KHz	6.4KHz	7.0KHz	8.0KHz
AMSRC010A	15.0 秒	12.0 秒	11.3 秒	10.0 秒	9.4 秒	8.6 秒	7.5 秒
AMSRC015A	22.5 秒	18.0 秒	17.0 秒	15.0 秒	14.1 秒	12.9 秒	11.3 秒
AMSRC020A	30.0 秒	24.0 秒	22.6 秒	20.0 秒	18.8 秒	17.2 秒	15.0 秒

- (5) 內建低通濾波器線路(LPF)。
- (6) 可錄一段或兩段信息，有兩種模式可用來決定每段的錄音長度： 固定時間分段 和 不固定時間分段。
(此功能可由 Opt_F 腳來做 Bonding 選擇)
- (7) 有四個輸入按鍵供錄音和放音使用。
 - Rec_E: Edge/Unhold 觸發錄音，具有Toggle on/off 功能。
 - Rec_L: Level/Hold 觸發錄音。
 - Play_E: Edge/Unhold 觸發放音，具有Toggle on/off 功能。**(當持續按住此按鍵時，錄音信息會連續播放)**
 - Play_L: Level/Hold 觸發放音。
- (8) 有兩個輸出訊號來分別顯示錄音和放音，可用來接LED或推馬達。
 - Out_P: 放音時輸出訊號。
 - Out_R: a) 錄音時輸出訊號。
b) 留言指示功能，只有在錄完音後且尚未進行第一次放音前才會啟動此功能，約0.5Hz的閃爍頻率。**(此功能可由 Opt_N 腳來做 Bonding 選擇)**
- (9) 在開始錄音時會先有一聲'嗶'聲提示，而當記憶體耗盡或停止錄音時則會有兩聲'嗶'聲提示。**(此功能可由 Opt_B 腳來做 Bonding 選擇)**
- (10) 可選擇的單端或雙端PWM輸出，雙端PWM輸出可直接推動喇叭或蜂鳴片。
- (11) 數位串列輸入/輸出，可用來預錄或輸出信息。**(如需使用此特殊功能，請聯絡佑華公司或其代理商)**

1.0 General Description

The AMSRC010A/AMSRC015A/AMSRC020A are simple SRAM recording/playback ICs. The duration of recording can be adjusted by changing the oscillation frequency. These devices can store one or two sections of message, and support both fixed and variable duration of dual messages. There is on-chip Low Pass Filter (LPF) to reduce the environment noise while recording. For low power consumption, they provide PWM output to drive speaker or buzzer directly. Except two recording/playback LED indicators, they also provide a special function of new message indicator. These devices are ideal for use in portable voice recorders, toys, and many other consumer applications.

2.0 Features

- (1) Single power supply can operate from 2.4~5.5V.
- (2) Oscillation mode: R oscillator.
- (3) Low standby current, <1uA@3V.
- (4) Built-in SRAM for voice recording. Adjust OSC resistor value from 4k~8KHz sample rate to select different voice duration.

	4.0KHz	5.0KHz	5.3KHz	6.0KHz	6.4KHz	7.0KHz	8.0KHz
AMSRC010A	15.0 sec	12.0 sec	11.3 sec	10.0 sec	9.4 sec	8.6 sec	7.5 sec
AMSRC015A	22.5 sec	18.0 sec	17.0 sec	15.0 sec	14.1 sec	12.9 sec	11.3 sec
AMSRC020A	30.0 sec	24.0 sec	22.6 sec	20.0 sec	18.8 sec	17.2 sec	15.0 sec

- (5) Built-in Low Pass Filter (LPF) circuits.
- (6) One or two recording sections. Two kinds of methods to define recording duration for each section: One is Fixed-duration, another is Variable-duration. ***(This function is bonding-option by Opt_F pad)***
- (7) Four input triggers for recording and playback.
 - Rec_E: Edge/Unhold trigger for voice recording, Toggle on/off function.
 - Rec_L: Level/Hold trigger for voice recording.
 - Play_E: Edge/Unhold trigger for voice playback, Toggle on/off function. ***(Continuously playing voice if keeping key pressed)***
 - Play_L: Level/Hold trigger for voice playback.
- (8) Two output signal for recording/playback indicator which can drive LED or motor.
 - Out_P: Active while playback only.
 - Out_R: a) Active while recording.
b) New message indicator, active before 1st-time playback, 0.5Hz flashing rate. ***(This function is bonding-option by Opt_N pad)***
- (9) Play 'Bi' sound at the beginning of recording and play 'Bi-Bi' sound while memory full or recording stop. ***(This function is bonding-option by Opt_B pad)***

- (10) User-selectable 1-ended/2-ended PWM output.
- (11) Digital Serial Input/Output for pre-recording message and data output. (*Contact Alpha or her agent for this special function.*)

3.0 Block Diagram

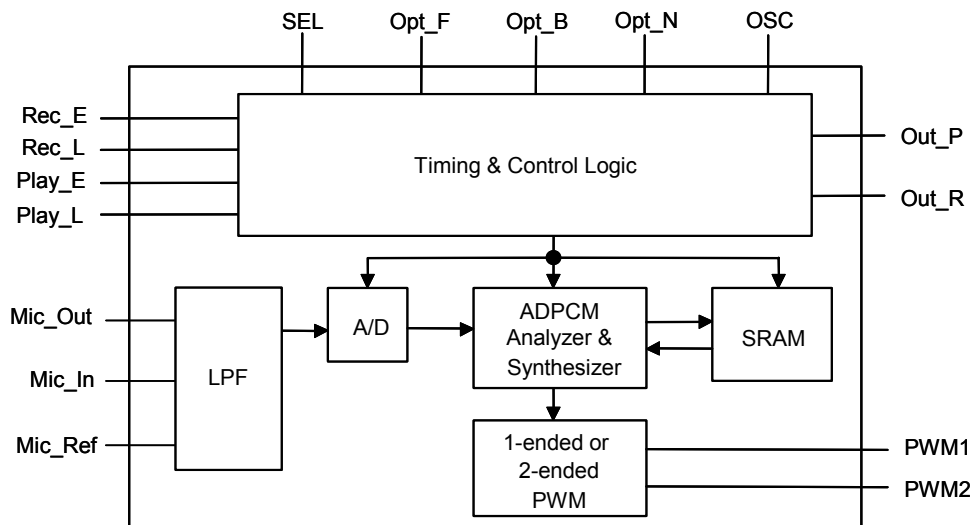

4.0 Pad Description

Pad Name	Pin Attr.	Description
VDD1~2	Power	Positive power
GND1~2	Power	Negative power
OSC	I	R oscillator input
PWM1	O	PWM1 output. / Connect this pin to GND when 1-ended PWM output.
PWM2	O	PWM2 output. / 1-ended PWM output.
Mic_Ref	I	Microphone input as voltage reference
Mic_In	I	Microphone input as MIC pre-amplifier
Mic_Out	O	Microphone output as MIC pre-amplifier
Rec_E	I	Trigger input for recording, <i>Edge/Unhold/Irretrigger</i> mode. (i.e. One-shot)
Rec_L	I	Trigger input for recording, <i>Level/Hold</i> mode.
Play_E	I	Trigger input for playback, <i>Edge/Unhold/Irretrigger</i> mode. (i.e. One-shot)
Play_L	I	Trigger input for playback, <i>Level/Hold</i> mode.
SEL	I	Select pin to select 1st section (VDD) or 2nd section (GND).
Test	I	Test pin for internal test.
Out_P	O	Playback indicator, low active.
Out_R	O	Recording indicator, low active. New message indicator, low active only if there is a new message existed.
OPT_B	I	Option pin for "Bi sound" enable(VDD)/Disable(GND).
OPT_N	I	Option pin for "New message indicator" enable(VDD)/Disable(GND).
OPT_F	I	Option pin for fixed-duration(VDD)/variable-duration(GND) section.

** If you only want one section of message, just connect OPT_F pin to GND and fix SEL pin to VDD or GND.*

5.0 DC Characteristics (at $R_{osc}=560k\Omega$, $SR=6kHz$)

Symbol	Parameter	VDD	Min.	Typ.	Max.	Unit	Condition
VDD	Operating voltage	-	2.4	3	5.5	V	Depending on Freq.
I_{sb1}	Standby1	3	-	-	1	uA	Sleep mode, Message Indicator OFF.
		4.5	-	-	2		
I_{sb2}	Standby2	3	-	3.5	-	uA	Sleep mode, Message Indicator ON, No load.
		4.5	-	7.5	-		
I_{op1}	Operating1	3	-	0.8	-	mA	Recording, No load
		4.5	-	4.2	-		
I_{op2}	Operating2	3	-	0.2	-	mA	Playback, No load
		4.5	-	0.3	-		
I_{il}	Input current (Internal pull-high $300k\Omega$)	3	-	6	-	uA	$V_{il}=0v$
		4.5	-	17	-		
I_{ol}	Output-low current (Open-drain)	3	-	24	-	mA	$V_{ol}=0.75V$
		4.5	-	52	-		$V_{ol}=1.50V$
I_{PWM}	PWM output current	3	-	40	-	mA	Load=8 ohms
		4.5	-	60	-		
dF/F	Frequency stability		-5	-	5	%	$\frac{F_{osc}(5.5v) - 2.4v}{F_{osc}(5.5v)}$
dF/F	Fosc lot variation		-10	-	10	%	Different lot wafer

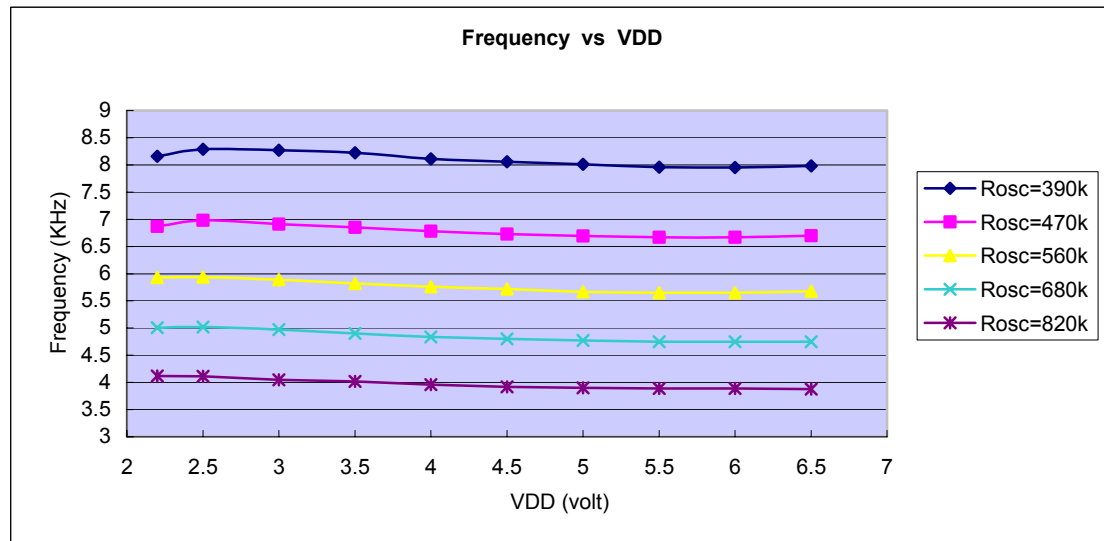
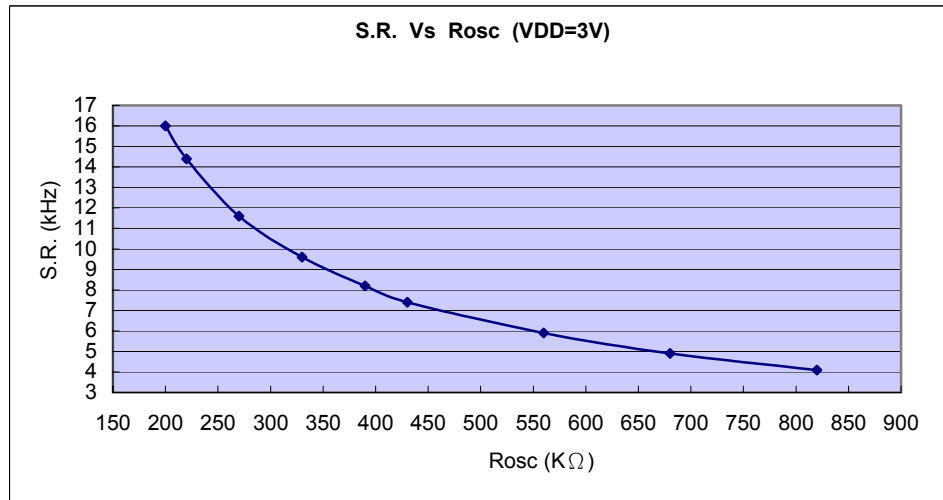

6.0 Timing Diagram

(1) Debounce Time

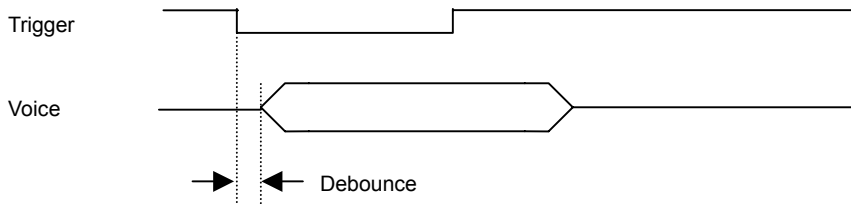

※ Debounce time is configured by 6 kHz S.R and the value is fixed. That is, Slow debounce=20ms. **(No Fast debounce)**

(2) Recording Mode

(a). Edge Trigger

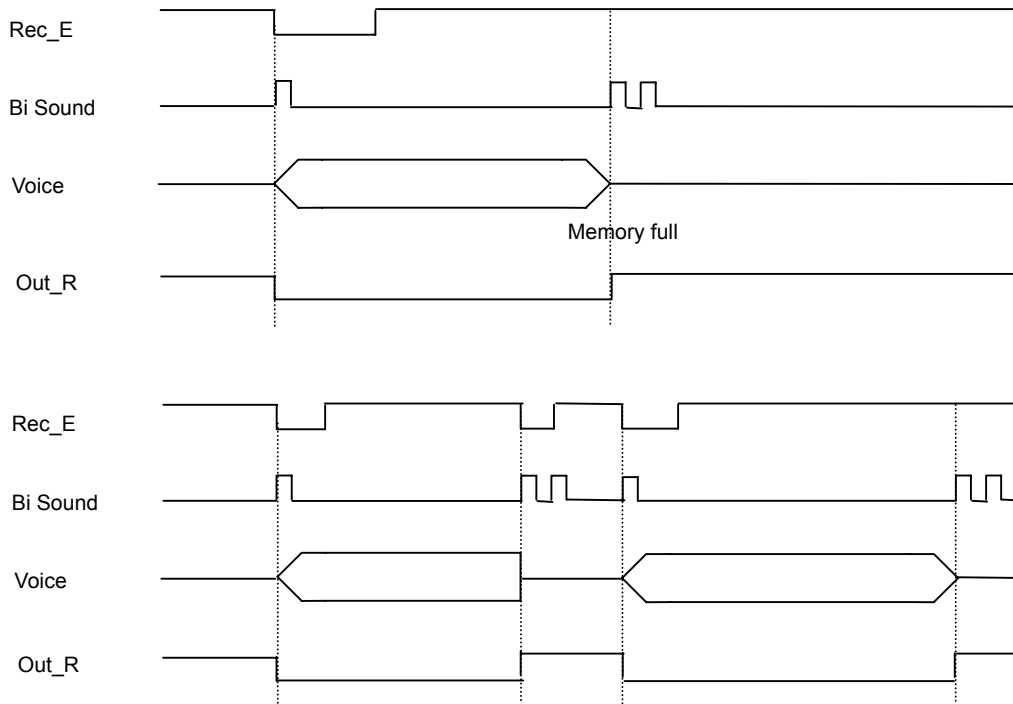

(b). Level Trigger

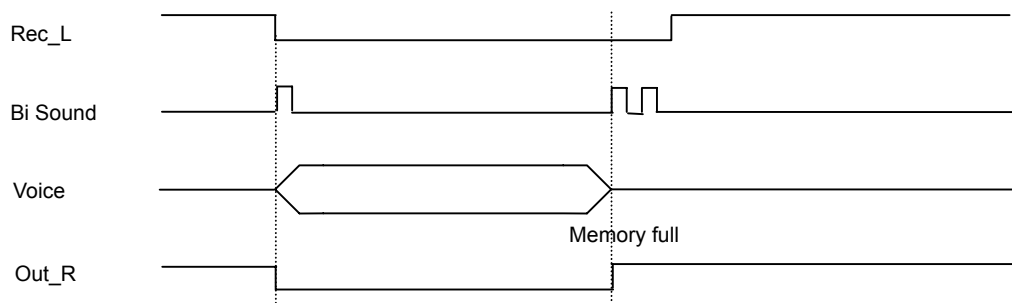

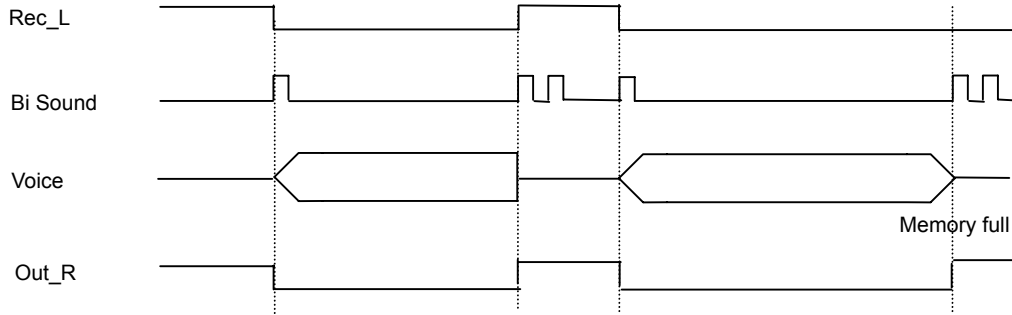

(3) Playback Mode

(a). Edge Trigger

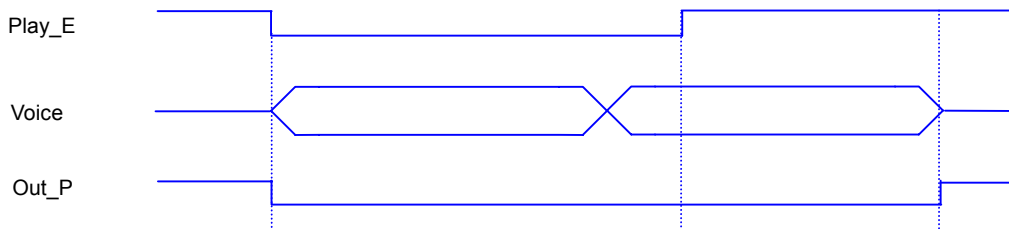

* Voice will be played continuously if keeping key pressed.

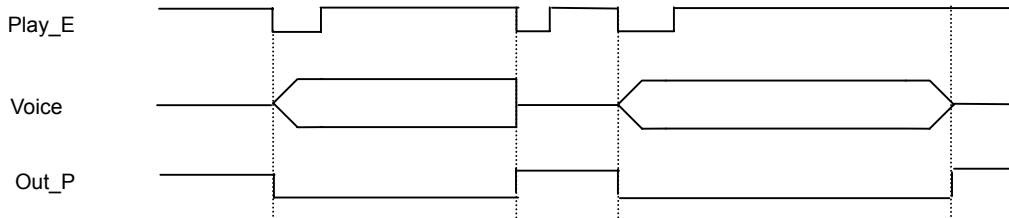

(b). Level Trigger

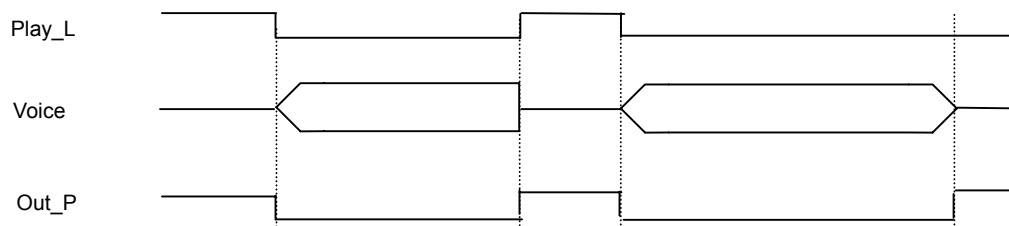
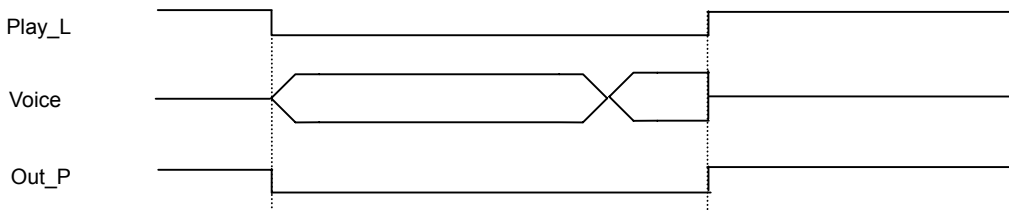

7.0 Application Circuit

a. PWM Direct Drive (MIC_SPK Alone, 2-Ended PWM)

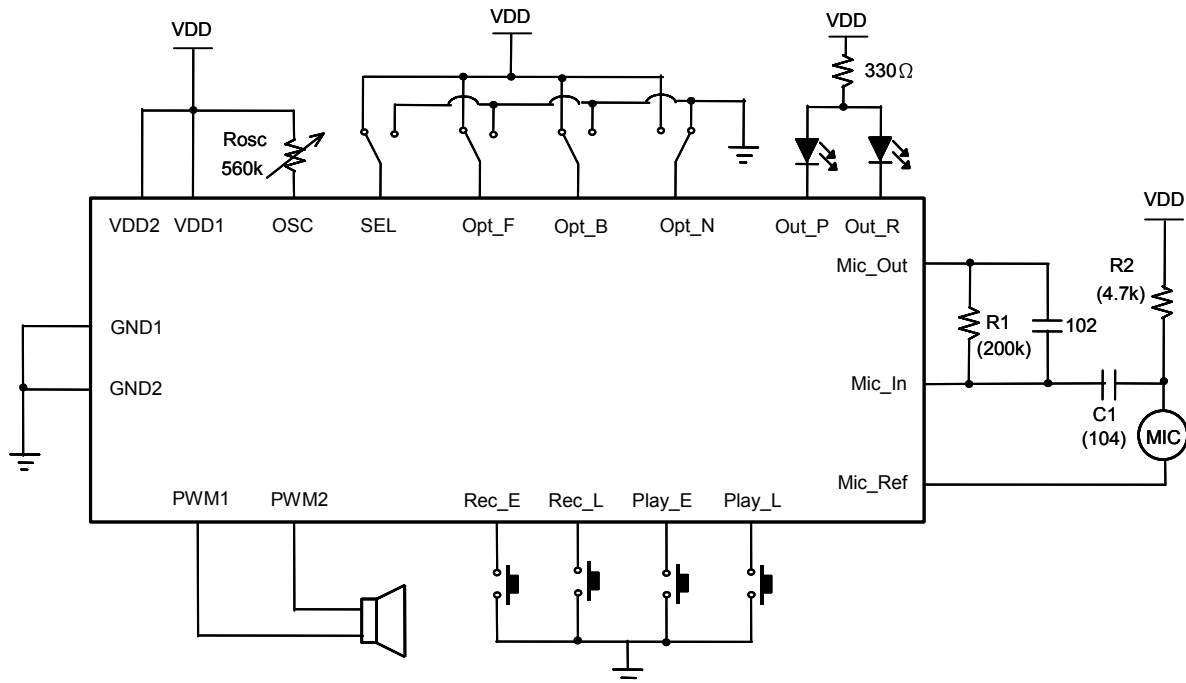

* R1 is used to control the gain of OP-Amp. A bigger R1 value will lead to larger voice volume. (100K~300K Ω)

* R2 is used to match the different microphone. A bigger R2 value will lead to larger voice volume and noise. (2K~4.7K Ω)

* C1 is used to control the gain and noise. A bigger C1 value will lead to larger voice volume and noise. (0.033u~0.1uF)

b. PWM Direct Drive (MIC_SPK Shared, 2-Ended PWM)

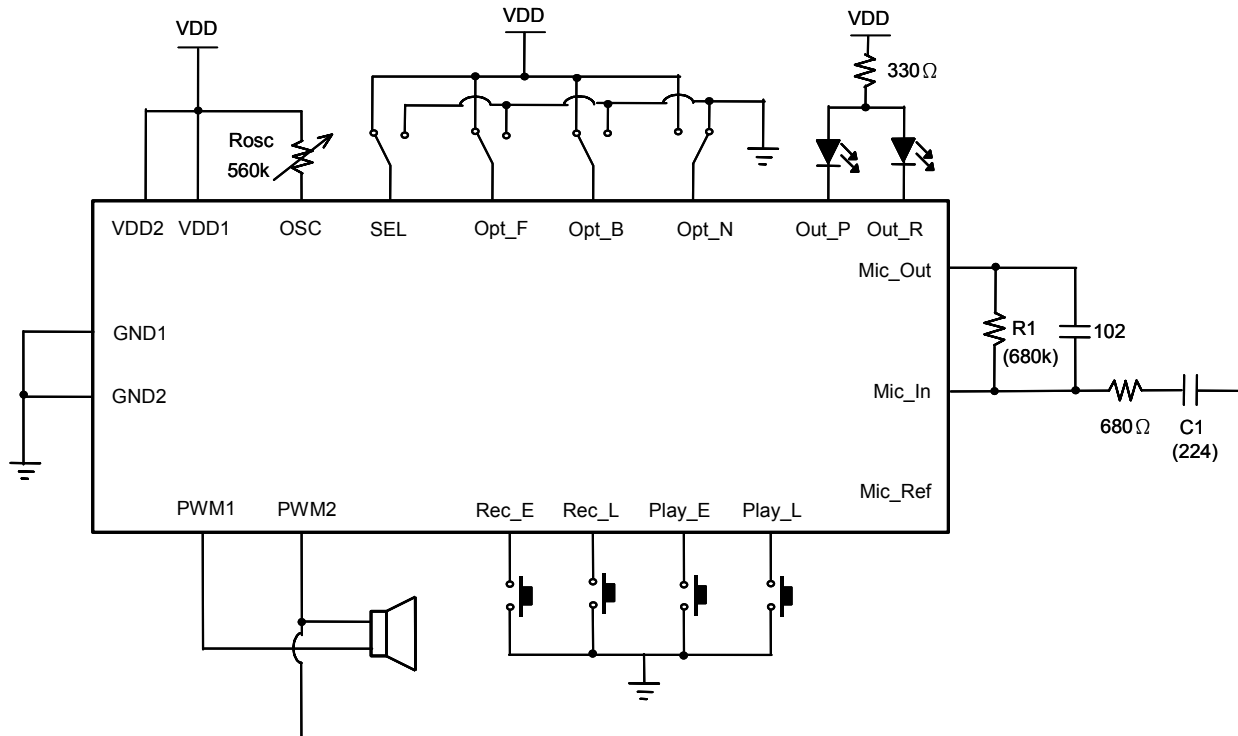

* R1 is used to control the gain of OP-Amp. A bigger R1 value will lead to larger voice volume. (470K~820K Ω)

* C1 is used to control the gain and noise. A bigger C1 value will lead to larger voice volume and noise. (0.1u~0.22uF)

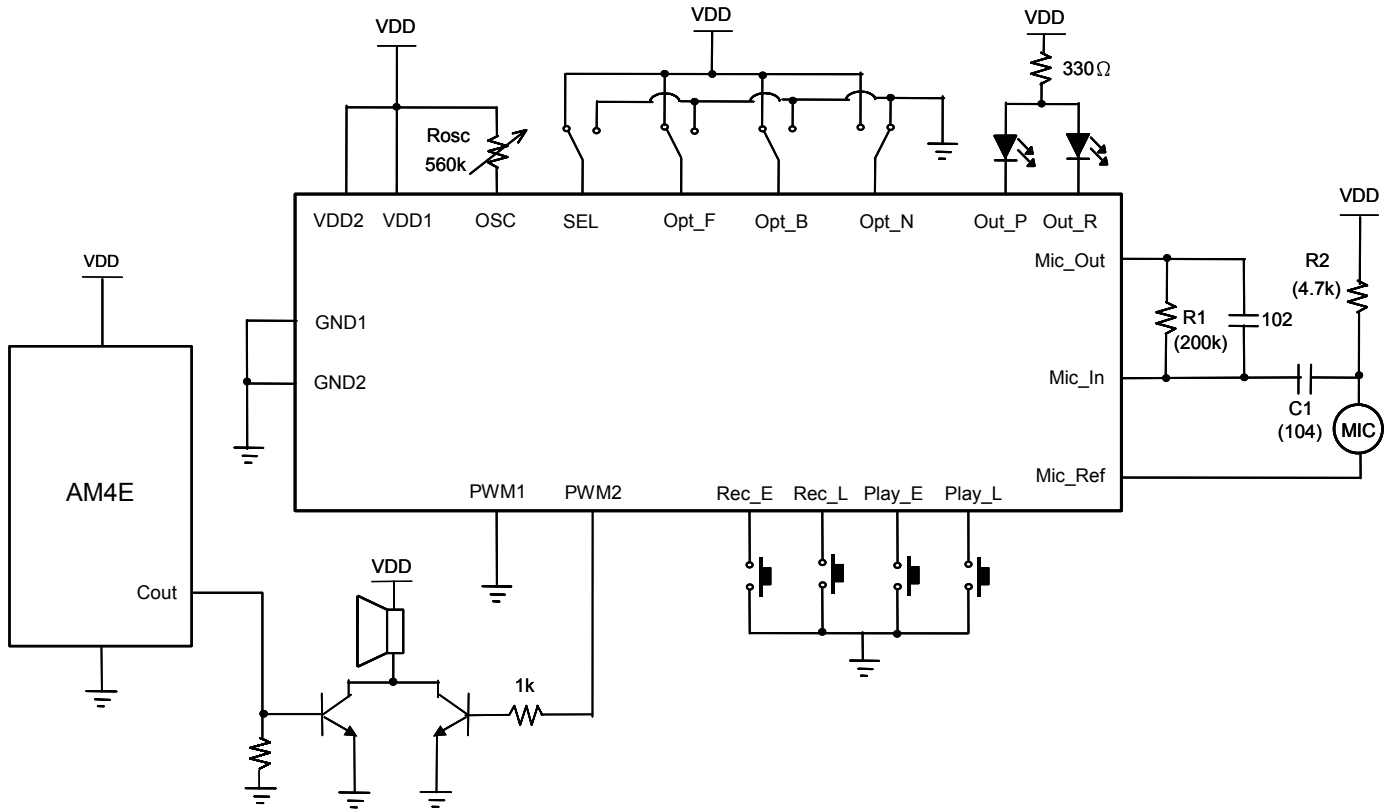
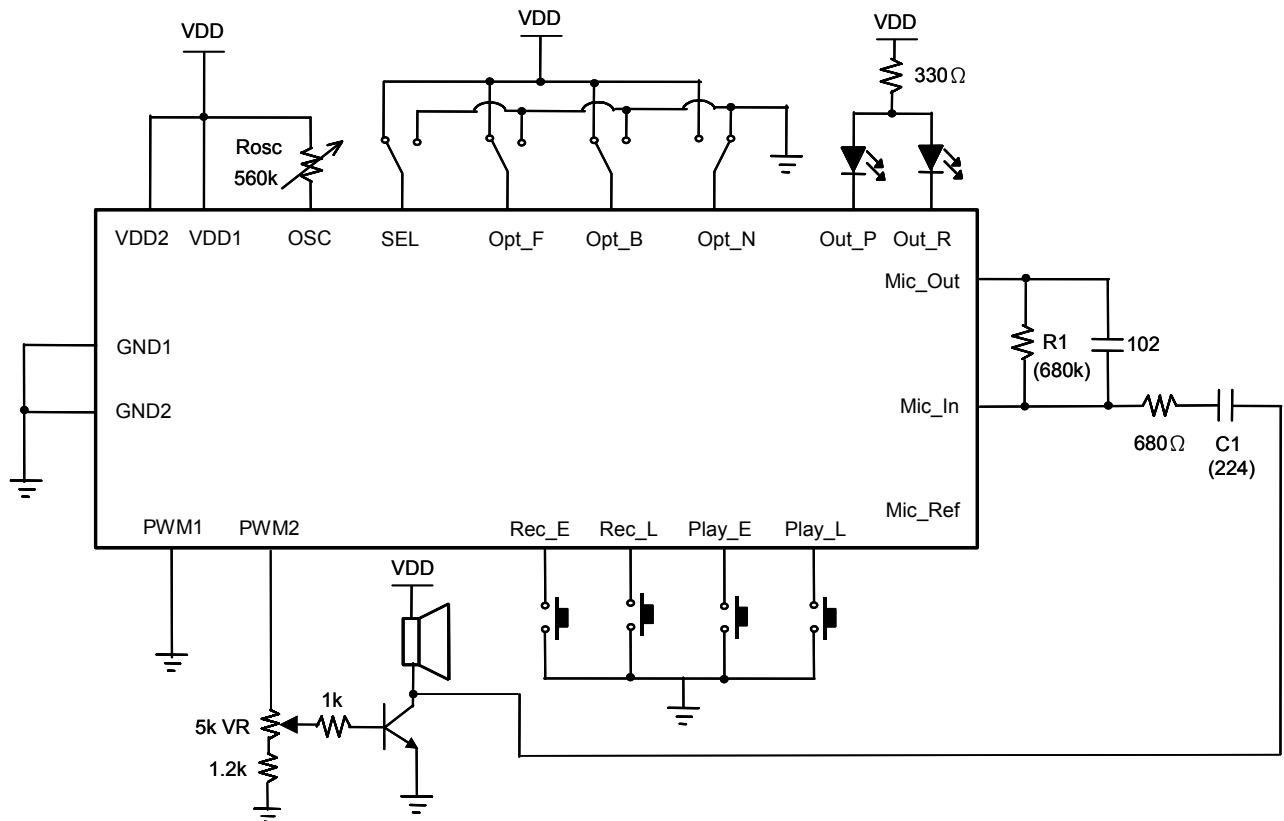
c. Mixing with AM4E Cout (MIC_SPK Alone, 1-Ended PWM)

d. Volume Control (MIC_SPK Shared, 1-Ended PWM)

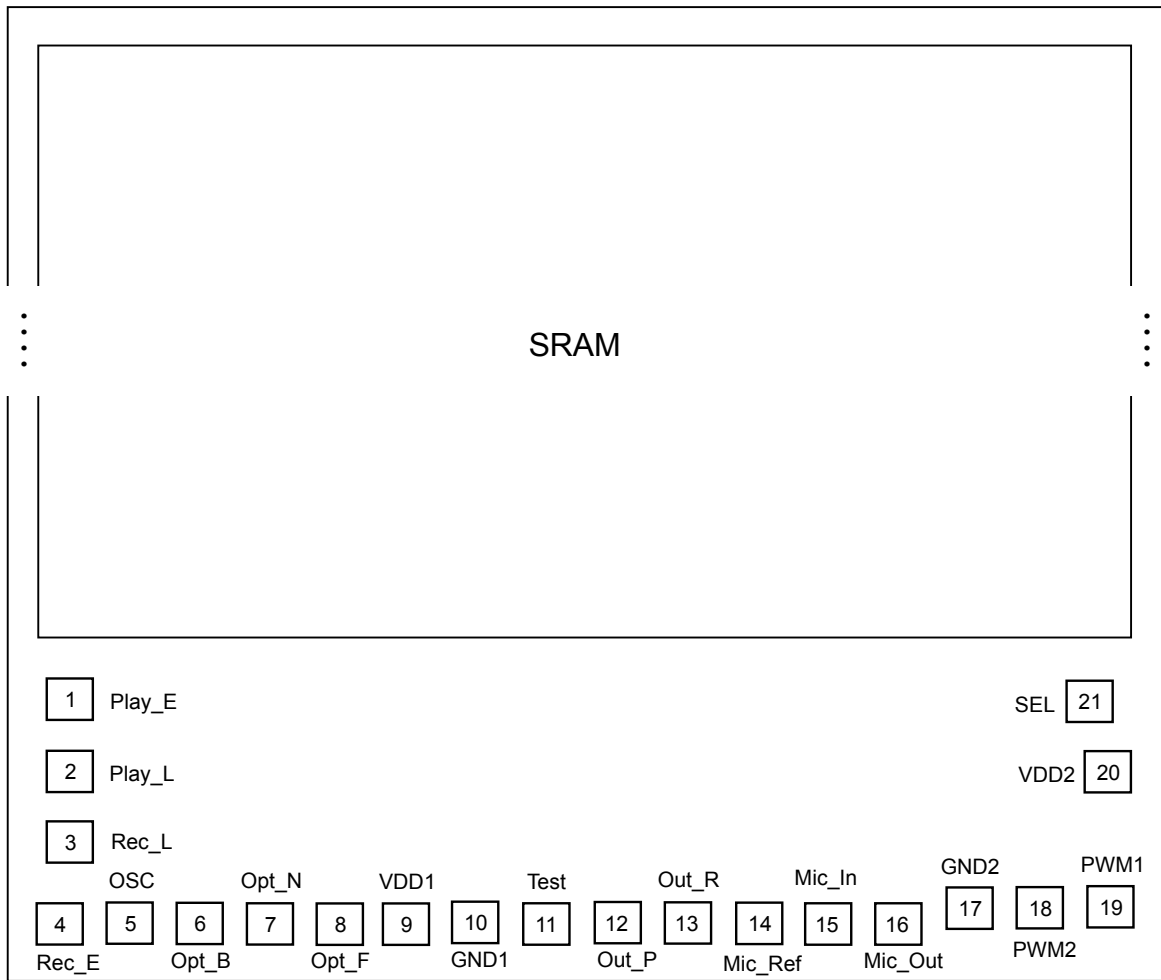
8.0 Bonding Diagram



(0, 0)

* The IC substrate must be connected to VDD.

Pad #	Pad Name	X	Y	Pad #	Pad Name	X	Y
1	Play_E	85	465	12	Out_P	1000	85
2	Play_L	85	345	13	Out_R	1116	85
3	Rec_L	85	225	14	Mic_Ref	1238	85
4	Rec_E	71	85	15	Mic_In	1363	85
5	OSC	198	85	16	Mic_Out	1474	85
6	Opt_B	308	85	17	GND2	1584	104
7	Opt_N	424	85	18	PWM2	1695	108
8	Opt_F	540	85	19	PWM1	1816	108
9	VDD1	657	85	20	VDD2	1819	309
10	GND1	767	85	21	SEL	1794	425
11	Test	877	85				