



Alpha Microelectronics Corp.

AM4HA OTP SERIES

Data Sheet

佑華微電子股份有限公司

新竹市光復路二段 295 號 9 樓之 1 號

電話: 03-573 6660

傳真: 03-573 6661

www.ealpha.com.tw

Alpha Microelectronics Corp.

9F-1, 295, Sec. 2, Kuang Fu Rd., Hsinchu, Taiwan

Tel : +886-3-573 6660

Fax: +886-3-573 6661

www.ealpha.com.tw

Revision History

<i>Rev</i>	<i>Date</i>	<i>Description</i>	<i>Page</i>
1.00	2008/3/14	Initial release	-
1.01	2008/4/2	1. Modify Section 5.1 AM4HA200A Application Circuit.	9
		2. Modify Section 6.1 AM4HA200A Bonding Diagram.	11
		3. Add Chap 7 ~ 8: AM4HA200A, AM4HA250A Package.	13

1. General Description

The AM4HA OTP series is a low-cost OTP-based, high performance 2-channel wavetable synthesizer with a powerful 4-bit microprocessor. There are various features including the 4-bit ALU, ROM, RAM, I/O ports, timers, interrupt, clock generator, wavetable and voice synthesizer, direct-drive outputs, etc. Watchdog timer (WDT), low voltage detector (LVDT), and infrared ray transmitter (IR) features improve system cost and reliability. Large current and open-drain outputs make their application diversified. Furthermore, with CMOS technology, the HALT and STB functions can minimize power dissipation.

The RISC MCU architecture is very easy to program and control. There are 66 instructions in these devices, and most of them are executed in only single cycle. The powerful instruction set makes users developing products easily and quickly. They are also equipped with a fine resolution Push-Pull audio output.

Due to the advantage of its free of code mask, it is not only to save the mask charge, and it also reduces the lead-time greatly.

2. Features

- a) 4-bit MCU with 71 instructions, which are 12-bit wide.
- b) They support 8 / 16 MHz system clock, and 2 / 4 MHz high-speed instruction cycle. Resistor mode (RM) only.
- c) The program and data share the same ROM space. The maximum ROM size is up to 4Kx12-bit.

Product	Notes	ROM Size (12-bit)	I/O
AM4HA200A	2000	3K	7
AM4HA250A	2500	4K	12

- d) There are 96 nibbles general purpose SRAM divided into 2 pages, and 48x4-bit in each page. Indirect SRAM addressing mode is supported.
- e) There is an embedded 2-ch wavetable synthesizer.
- f) 12-bit Push-Pull direct-drive audio output circuit is supported to provide best sound quality.
- g) 7 or 12 flexible I/O pads, which are divided into 2 or 3 port groups. The ports are named from PRA[3:0], PRB[3:0] to PRC[3:0]. Two types of input and two types of output are optional for each I/O port. For input, it supports with or without a pull-high resistor and can be wake-up port. For output, it supports to normal output or open-drain configuration.
- h) 11-bit SR timer for each channel can provide super fine pitch frequency resolution for 0.125us @8MHz system clock or 0.0625us @16MHz system clock.

- i) Timbres are formed by 64 samples 6-bit PCM. They are auto repeated by the specified SR to synthesis notes easily. In addition to the melody mode, they support voice mode and single channel mode also.
- j) IR mode and reset mode are supported for PRA[3], PRB[3] and PRBC[3]. It even supports code option to disable the I/O ports except PRA. For IR mode, it further supports low or high carry mode (37KHz / 38.5KHz optional by code). For reset mode, it further supports with or without a pull-high resistor.
- k) HALT and STB instructions are both supported for power saving.
- l) One interrupt with an independent stack is supported. There are 4 different length options of the fixed periods, and this is programmable by register. The range is from 0.125ms to 1ms.
- m) Low voltage reset, watchdog reset, and I/O port reset are all supported to protect the system.

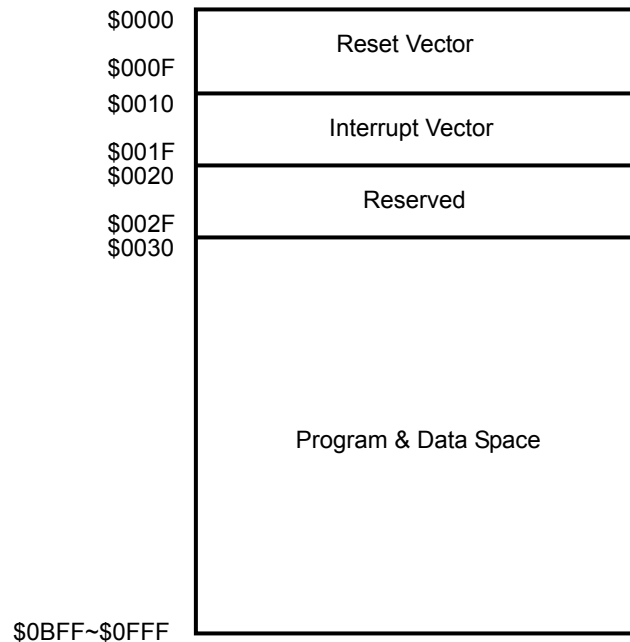

FIGURE 1: ROM Map of AM4HAxxxx

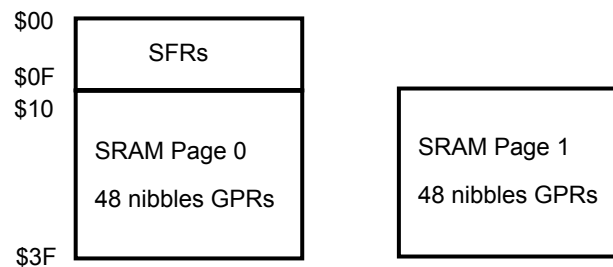
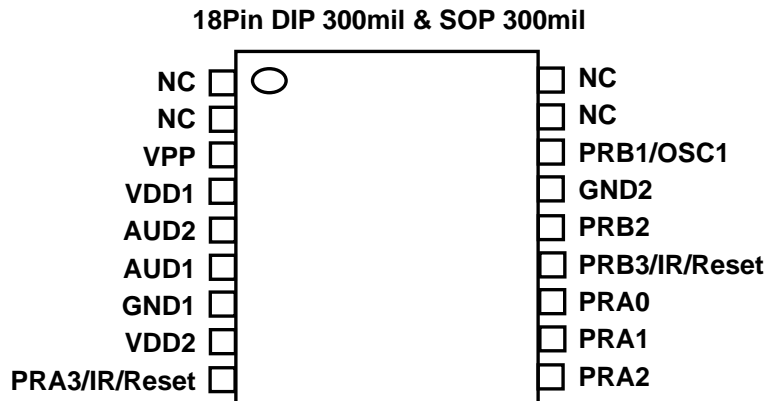

FIGURE 2: SRAM Map of AM4HAxxxx

3. Pin

3.1 AM4HA200A Pin Description



Pad Name	Attr.	Description
PRA0~2	I/O	Four I/O modes can be optioned for each I/O pin: (1) Floating input mode, (2) pull-high input mode, (3) normal output , (4) open-drain. <i>Or 2 kinds of output current: (1) Normal current, (2) Large current.</i>
PRA3 / IR / Reset	I/O	Four I/O modes can be optioned for each I/O pin: (1) Floating input mode, (2) pull-high input mode, (3) normal output, (4) open-drain. <i>Or 2 kinds of output current: (1) Normal current, (2) Large current.</i> <i>Or mask_option selected as an IR Carrier Output with programmable 37k / 38.5kHz or an external RESET pin with weak pull-high capability.</i>
PRB1 / OSC1	I/O	Four I/O modes can be optioned for each I/O pin: (1) Floating input mode, (2) IO mode, (3) pull-high input mode, (4) output mode. <i>Or R oscillator input for RM mode.</i>
PRB2	I/O	Four I/O modes can be optioned for each I/O pin: (1) Floating input mode, (2) pull-high input mode, (3) normal output , (4) open-drain.
PRB3 / IR / Reset	I/O	Four I/O modes can be optioned for each I/O pin: (1) Floating input mode, (2) pull-high input mode, (3) normal output , (4) open-drain. <i>Or mask_option selected as an IR Carrier Output with programmable 37k / 38.5kHz or an external RESET pin with weak pull-high capability.</i>
AUD1	O	Push-Pull-DAC Output of Audio 1.
AUD2	O	Push-Pull-DAC Output of Audio 2.
VDD1~2	Power	Positive power supply.
VPP	Power	Program power supply
GND1~2	Power	Ground Potential.

3.2 AM4HA250A Pin Description

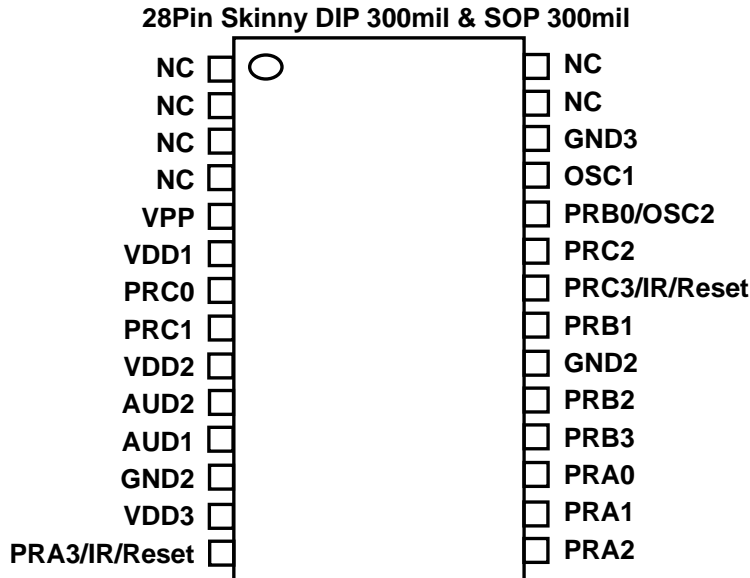

Pad Name	Attr.	Description
PRA0~2	I/O	Four I/O modes can be optioned for each I/O pin: (1) Floating input mode, (2) pull-high input mode, (3) normal output , (4) open-drain. <i>Or 2 kinds of output current: (1) Normal current, (2) Large current.</i>
PRA3 / IR / Reset	I/O	Four I/O modes can be optioned for each I/O pin: (1) Floating input mode, (2) pull-high input mode, (3) normal output , (4) open-drain. <i>Or 2 kinds of output current: (1) Normal current, (2) Large current.</i> <i>Or mask_option selected as an IR Carrier Output with programmable 37k / 38.5kHz or an external RESET pin with weak pull-high capability.</i>
PRB0 / OSC2	I/O	Four I/O modes can be optioned for each I/O pin: (1) Floating input mode, (2) IO mode, (3) pull-high input mode, (4) output mode. <i>Or crystal output for HM mode.</i>
PRB1~2 / PRC0~2	I/O	Four I/O modes can be optioned for each I/O pin: (1) Floating input mode, (2) pull-high input mode, (3) normal output , (4) open-drain.
PRB3 / PRC3 / IR / Reset	I/O	Four I/O modes can be optioned for each I/O pin: (1) Floating input mode, (2) pull-high input mode, (3) normal output , (4) open-drain. <i>Or mask_option selected as an IR Carrier Output with programmable 37k / 38.5kHz or an external RESET pin with weak pull-high capability.</i>
OSC1	I	Oscillator input for RM/HM mode.
AUD1	O	Push-Pull-DAC Output of Audio 1.
AUD2	O	Push-Pull-DAC Output of Audio 2.
VDD1~3	Power	Positive power supply.
VPP	Power	Program power supply
GND1~3	Power	Ground Potential.

4. Electrical Characteristics

The characteristics of AM4HA OTP series are described in this section. All the data and graphics are measured in the room temperature. Different process lot or testing condition may cause variation of data result.

4.1 Absolute Maximum Rating

SYMBOL	RATING	UNIT
Vdd ~ Vss	-0.5 ~ +5.0	V
Vin (for all input)	Vss-0.3 < Vin < Vdd+0.3	V
Vout (for all output)	GND < Vout < Vdd	V
Top (Operating)	0 ~ +70	°C
Tst (Storage)	-25 ~ +85	°C

4.2 DC Characteristics

SYMBOL	PARAMETER	Vdd	MIN.	TYP.	MAX.	UNIT	CONDITION	
VDD	Operating voltage		2.4	3	5	V		
Iht	Supply current	Halt	3		1	uA	Halt mode	
			4.5		2			
Isb		Standby	3		47.2		uA	8MHz, Standby mode (1ms interrupt, RM)
			4.5		100.4			
			3		61.3			16MHz, Standby mode (1ms interrupt, RM)
			4.5		125.3			
Iop		Operating	3		2.0		mA	8MHz, RM, D/A stop I/O No Loading
			4.5		2.5			
			3		3.0			16MHz, RM, D/A stop I/O No Loading
			4.5		4.0			
Iil		Input current (Internal weak pull-high)	3		-3.2		uA	Vil=0v
			4.5		-8.3			
Ioh	Output high current	3		-12.2		mA	Voh=2.5v	
		4.5		-25.6			Voh=3.4v	
Iol	Output low current (Normal current)	3		12.8		mA	Vol=0.6v	
		4.5		23.6			Vol=1.15v	
Iol	Output low current (Large current)	3		24.5		mA	Vol=1.05v	
		4.5		44.9			Vol=1.10v	
IAUD1 IAUD2 (Two End)	Push-Pull output current	3		44.3		mA	8Ω speaker	
		4.5		92.1				
IAUD1 (One End)	Push-Pull output current	3		14		mA	8Ω speaker	
		4.5		60				
dF/F	Frequency stability	3		4.5		%	$\frac{F_{osc}(5v) - F_{osc}(3v)}{F_{osc}(5v)}$	

4.3 Typical Rosc vs. Vdd for RM Mode Oscillator

Vdd	Oscillator Frequency				
	Rosc=430K	Rosc=360K	Rosc=270K	Rosc=220K	Rosc=180K
2.5 V	8.14MHz	9.30MHz	12.16MHz	14.30MHz	18.31MHz
3.0 V	8.34MHz	9.60MHz	12.51MHz	14.84MHz	18.47MHz
3.5 V	8.43MHz	9.81MHz	12.73MHz	15.06MHz	18.85MHz
4.0 V	8.54MHz	9.86MHz	12.83MHz	15.24MHz	19.11MHz
4.5 V	8.56MHz	9.95MHz	13.02MHz	15.31MHz	19.22MHz
5.0 V	8.60MHz	10.02MHz	13.12MHz	15.46MHz	19.38MHz
5.5 V	8.64MHz	10.03MHz	13.14MHz	15.59MHz	19.40MHz
6.0 V	8.73MHz	10.11MHz	13.19MHz	15.67MHz	19.50MHz

4.4 Interrupt period

Mode	INT Source (ms)	Vdd (V)	INT period (ms)
Operating	0.125	3	0.127
		4.5	0.132
	0.25	3	0.25
		4.5	0.262
	0.5	3	0.501
		4.5	0.524
1	3	1	
	4.5	1.05	
Standby (RM)	0.125	3	2.188
		4.5	2.407
	0.25	3	4.261
		4.5	4.647
	0.5	3	8.369
		4.5	9.245
	1	3	16.717
		4.5	18.463

5. Application Circuit

5.1 AM4HA200A Application Circuit

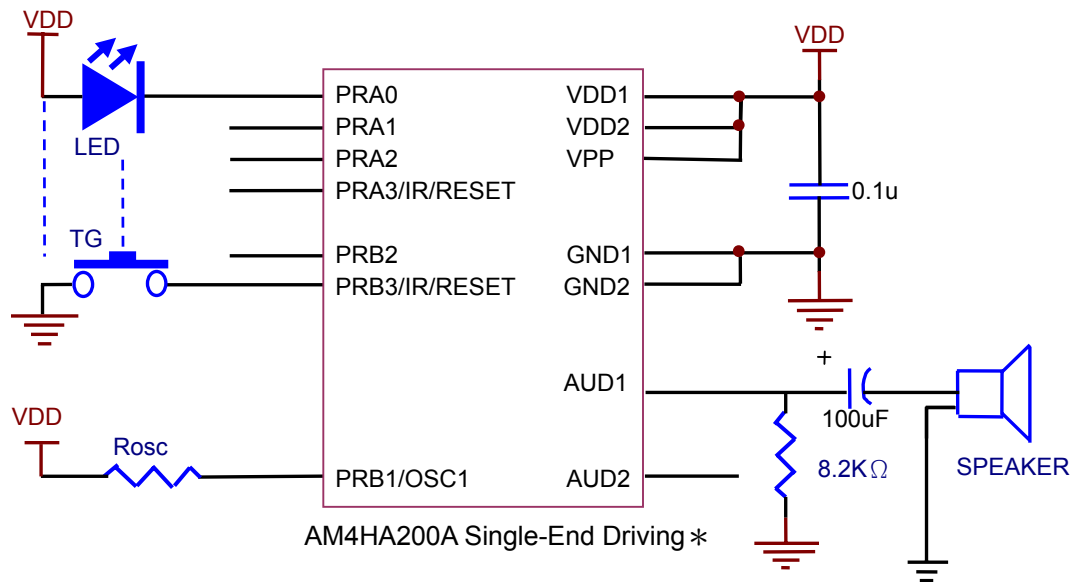
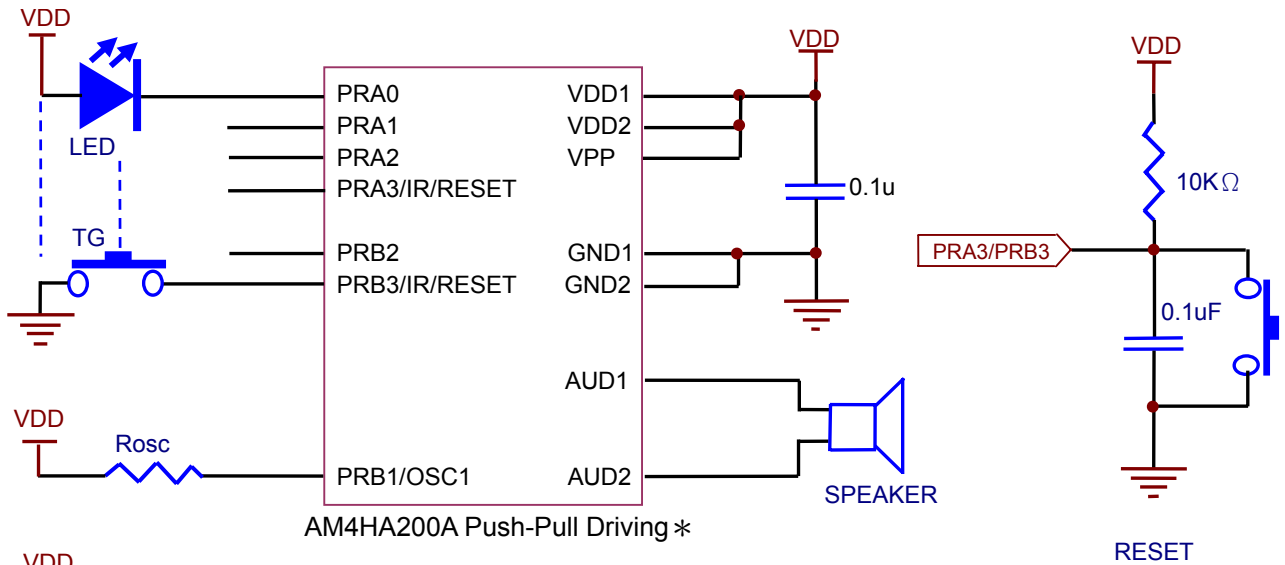

*** Note:**

Sound volume is smaller but softer while using Single_End Driving Application, whereas Push-Pull Driving application enlarges sound volume as well as power consumption. Push-Pull Driving application is applicable with the 3V power supply (2 Alkaline batteries) operation environment. Please do not use Direct-Drive for Push-Pull Driving application with 4.5V power supply operation environment.

5.2 AM4HA250A Application Circuit

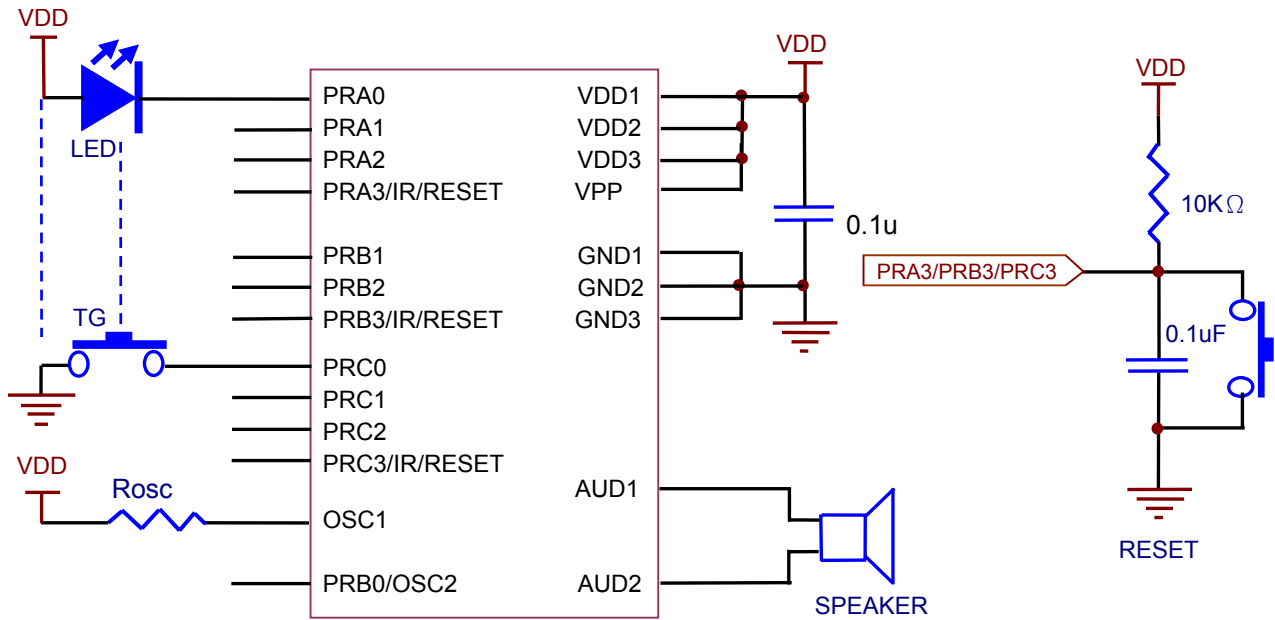

AM4HA250A Push-Pull Driving *

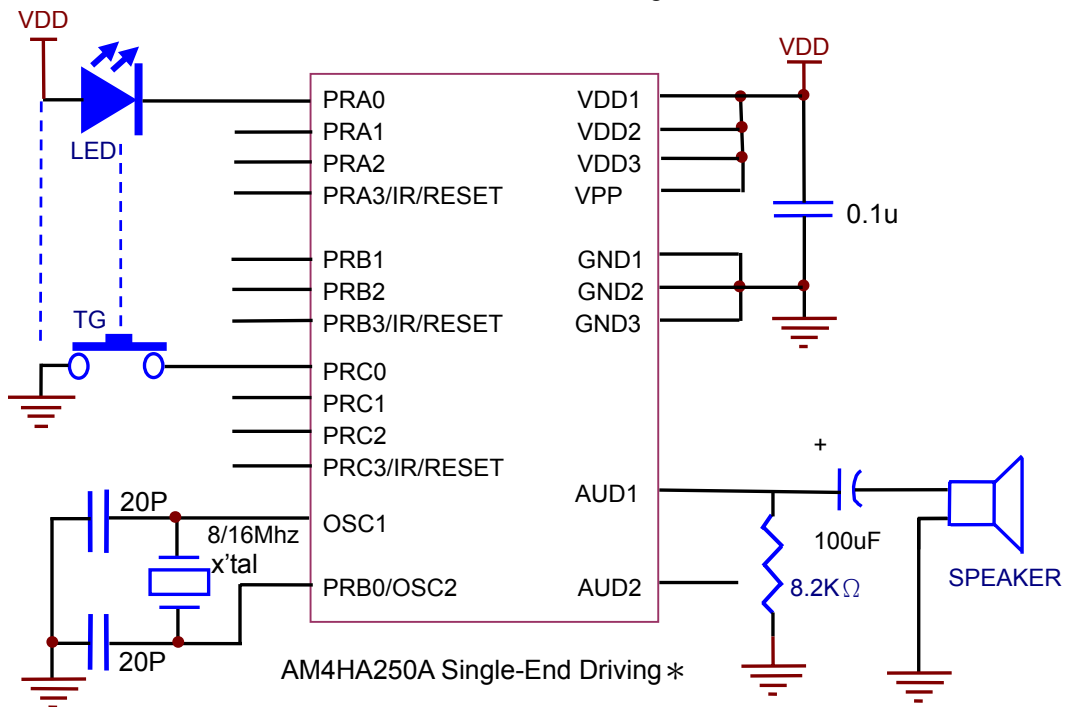

AM4HA250A Single-End Driving *

*** Note:**

Sound volume is smaller but softer while using Single_End Driving Application, whereas Push-Pull Driving application enlarges sound volume as well as power consumption. Push-Pull Driving application is applicable with the 3V power supply (2 Alkaline batteries) operation environment. Please do not use Direct-Drive for Push-Pull Driving application with 4.5V power supply operation environment.

6.2 AM4HA250A Bonding Diagram

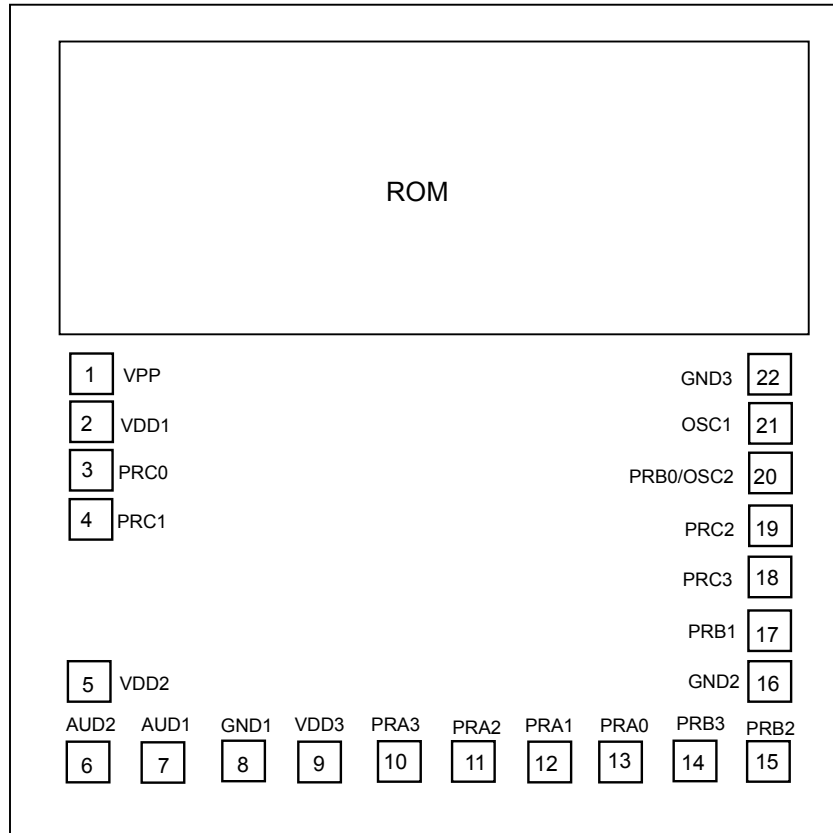

(0,0)

*** Note:** The IC substrate must be connected to GND.

Pad #	Pad Name	Pad #	Pad Name
1	VPP	12	PRA1
2	VDD1	13	PRA0
3	PRC0	14	PRB3 / IR / Reset
4	PRC1	15	PRB2
5	VDD2	16	GND2
6	AUD2	17	PRB1 / OSC2
7	AUD1	18	PRC3 / IR / Reset
8	GND1	19	PRC2
9	VDD3	20	PRB0
10	PRA3 / IR / Reset	21	OSC1
11	PRA2	22	GND3

7. Package Dimension of AM4HA200A

18Pin DIP 300 mil

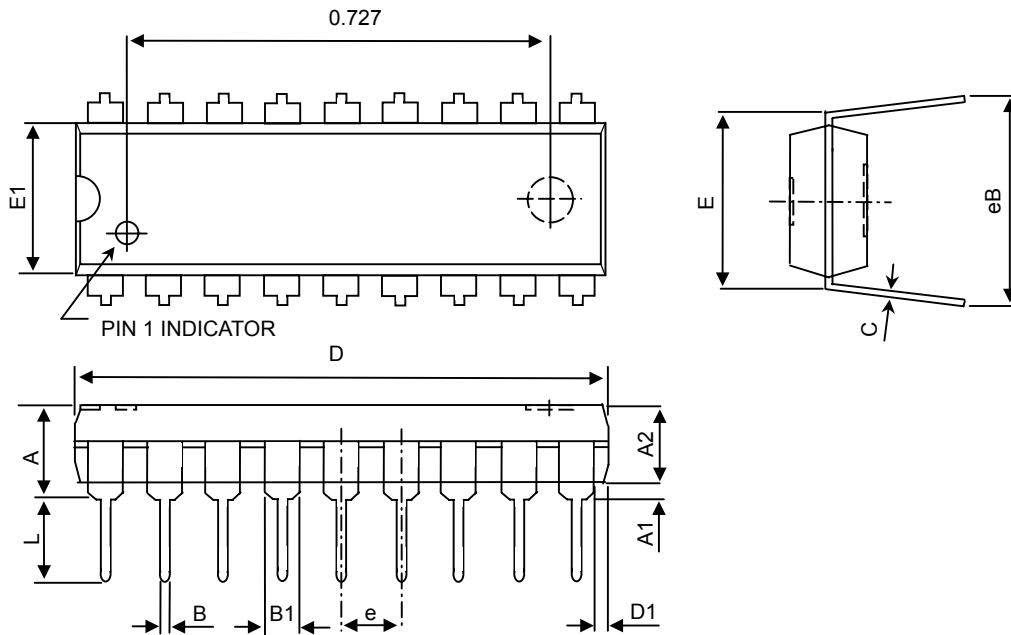

Symbols	Dimension In Millimeters			Dimension In Inches		
	Min	Nom	Max	Min	Nom	Max
A	-		4.75	-	-	0.18-
A1	0.38	-	-	0.015	-	-
A2	-	3.3	3.56	-	0.13	0.14
B	0.36	0.46	0.56	0.014	0.018	0.022
B1	1.27	1.52	1.78	0.05	0.06	0.07
C	0.2	0.25	0.33	0.008	0.01	0.013
D	22.71	22.96	23.11	0.894	0.904	0.91
E	7.62	-	8.26	0.017	0.022	0.027
E1	6.4	6.5	6.65	0.3	-	0.325
e	-	2.54	-	0.252	0.256	0.262
L	3.18	-	-	0.125	0.1	-
eB	8.38	-	9.65	0.33	-	0.38

18Pin SOP 300 mil

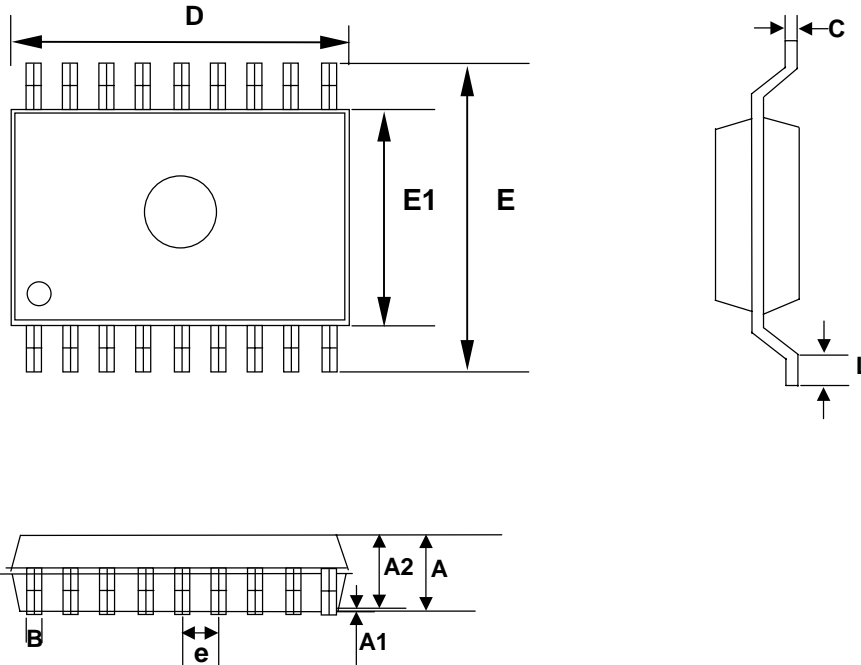

Symbols	Dimension In Millimeters			Dimension In Inches		
	Min	Nom	Max	Min	Nom	Max
A	2.415	2.515	2.615	0.095	0.099	0.103
A1	0.128	0.178	0.228	0.005	0.007	0.009
A2	2.287	2.337	2.387	0.09	0.092	0.094
B	-	0.406	-	-	0.016	-
C	-	0.254	-	-	0.01	-
D	11.482	11.532	11.582	0.452	0.454	0.456
E	10.21	10.31	10.41	0.402	0.406	0.41
E1	7.418	7.468	7.518	0.292	0.294	0.296
e	-	1.27	-	-	0.05	-
L	0.686	0.762	0.838	0.027	0.03	0.033

8. Package Dimension of AM4HA250A

28Pin Skinny DIP 300 mil

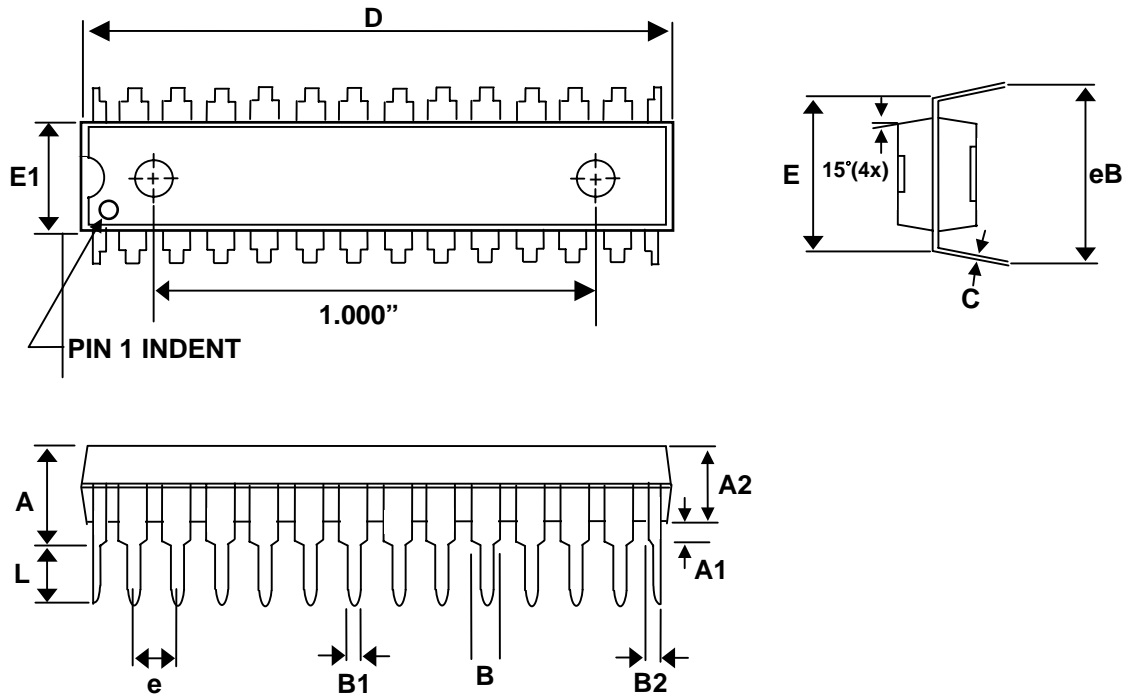

SYMBOLS	Dimension In Millimeters			Dimension In Inches		
	Min	Nom	Max	Min	Nom	Max
A	-	-	4.75	-	-	0.18
A1	0.38	-	-	0.015	-	-
A2	-	3.3	3.56	-	0.130	0.14
B	1.02	-	1.65	-	0.060	-
B1	0.41	-	0.58	0.004	-	0.065
C	0.2	0.25	0.33	0.016	-	0.023
D	35.13	35.18	35.43	1.383	1.385	1.395
E	7.87	8.31	8.38	0.31	0.327	0.33
E1	7.26	7.32	7.52	0.284	0.288	0.296
e	-	2.54	-	-	0.100	-
L	3.18	-	-	0.125	-	-
eB	8.64	-	6.95	0.340	-	0.38

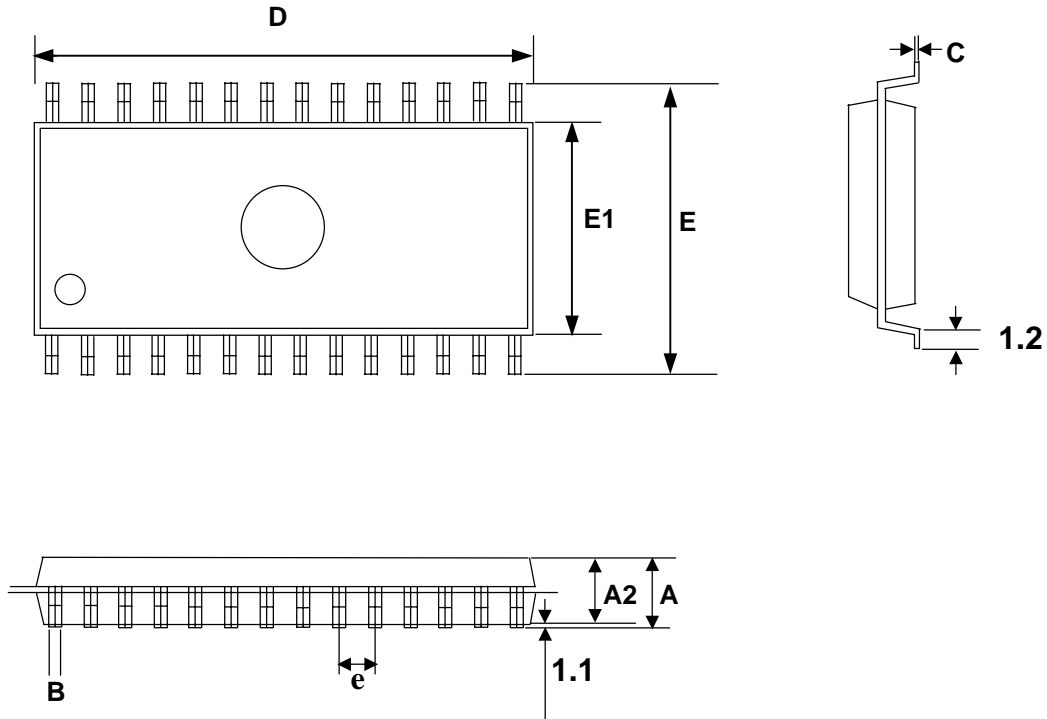
28Pin SOP 300 mil

Symbols	Dimension In Millimeters			Dimension In Inches		
	Min	Nom	Max	Min	Nom	Max
A	2.415	2.515	2.615	0.095	0.099	0.103
A1	0.1278	0.1778	0.2278	0.005	0.007	0.009
A2	2.287	2.337	2.387	0.090	0.092	0.094
B		0.406			0.016	
C		0.254			0.010	
D	17.731	17.831	17.881	0.698	0.702	0.704
E	10.21	10.31	10.41	0.402	0.406	0.410
E1	7.393	7.493	7.543	0.290	0.295	0.297
e		1.27			0.050	
L	0.686	0.762	0.838	0.027	0.030	0.033

28Pin SSOP 209 mil

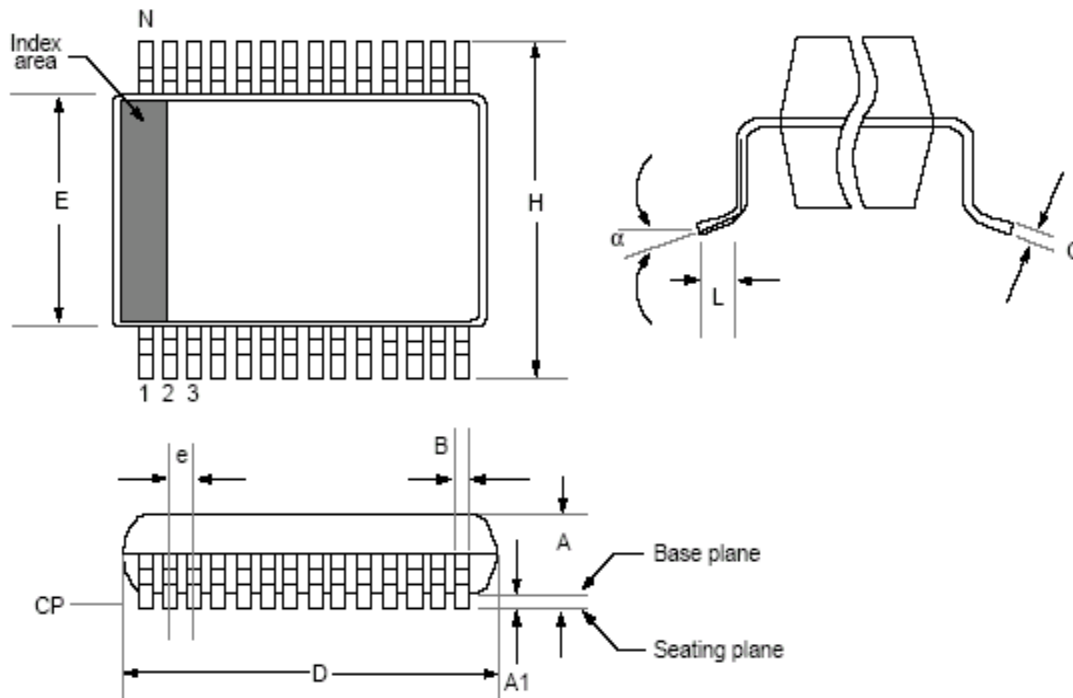

Package Group: Plastic SSOP						
Symbol	Millimeters			Inches		
	Min	Max	Notes	Min	Max	Notes
α	0°	8°		0°	8°	
A	1.730	1.990		0.068	0.078	
A1	0.050	0.210		0.002	0.008	
B	0.250	0.380		0.010	0.015	
C	0.130	0.220		0.005	0.009	
D	10.070	10.330		0.396	0.407	
E	5.200	5.380		0.205	0.212	
e	0.650	0.650	Reference	0.026	0.026	Reference
H	7.650	7.900		0.301	0.311	
L	0.550	0.950		0.022	0.037	
N	28	28		28	28	
CP	-	0.102		-	0.004	