



佑華微電子股份有限公司

AM4FE Series

DATA SHEET

佑華微電子股份有限公司

新竹市光復路二段 295 號 9 樓之 1 號

電話: 03-573 6660

傳真: 03-573 6661

www.ealpha.com.tw

Alpha Microelectronics Corp.

9F-1, 295, Sec. 2, Kuang Fu Rd., Hsinchu, Taiwan

Tel : +886-3-573 6660

Fax: +886-3-573 6661

www.ealpha.com.tw

Revision History

Revision	Date	Description	Page
1.1	2005/11/3	1. Modify page number. 2. Add and revise standby function description (Halt and Standby Mode). 3. Revise and add Isb Standby Mode Condition.	-
1.2	2005/12/14	Revise and add Iii (Input current) characteristics.	-
1.30	2009/12/7	1. Remove system clock 16MHz condition (Operating voltage and Standby mode). 2. PRF of AM4FE031B/AM4FE041B/AM4FE063B series don't support constant current. 3. Revise Vss ~ VDD characteristics.	4 8 9

Table of Contents

1. General Description	4
2. Features	4
3. Memory	6
3.1 ROM	6
3.2 SRAM	6
4. Pin Description	7
5. Electrical Characteristics	9
5.1 Absolute Maximum Rating.....	9
5.2 DC Characteristics.....	9
5.3 Typical Rosc and VDD for RM Mode Oscillator of AM4FExxxx	10
5.4 Typical DAC Output Current of AM4FExxxx (Full Scale for each DAC)	11
6. Application Circuit (AM4FE010B/015B/020B/031B/041B/063B)	12
7. Application Circuit (AM4FE084B/106B/127B)	13
8. Bonding Diagram	15
8.1 AM4FE010B/AM4FE015B/AM4FE020B/AM4FE031B/AM4FE041B/AM4FE063B	15
8.2 AM4FE084B/AM4FE106B/AM4FE127B	16

1. General Description

The AM4FExxxx series are very low cost midi & voice synthesizers with 4-bit microprocessor. They have various features including 4-bit ALU, ROM, RAM, I/O ports, timers, clock generator, MIDI and voice synthesizer, current D/A, Push-Pull and PWM outputs, etc. The audio synthesizer contains eight channels. Furthermore, they consist of 60 instructions in these devices. With CMOS technology, halt and standby function can minimize power dissipation. Their architectures are similar to RISC, with two stages of instruction pipeline. Most of instructions are executed in a single cycle, except for few instructions that need two or three instruction cycles.

2. Features

- (1) Single power supply can operate from 2.4V to 5.5V at 8MHz.
- (2) Program ROM can be up to 127k x 12-bit. (00000H~5FFFFH, 6 banks)
- (3) There are 9 bodies in AM4FE series:

Product	Voice Duration (sec)	ROM Size (12-bit)
AM4FE010B	10	32k
AM4FE015B	15	48k
AM4FE020B	20	64k
AM4FE031B	31	96k
AM4FE041B	41	128k
AM4FE063B	63	192k
AM4FE084B	84	256k
AM4FE106B	106	320k
AM4FE127B	127	384k

- (4) Data SRAM can be up to 448 x 4-bit. (20H~FFH per page, total 2 pages)
- (5) There are total 24 I/O pins, PRA/PRB/PRC/PRD/PRE/PRF. Each pin of all ports can be wake-up port when they are configured as input or IO mode.
- (6) There are two kinds of clock sources in the device of AM4F.
 - a) Resistor mode (**RM**).
 - b) High frequency crystal mode (**HM**).
- (7) Halt and Standby Mode

System clock can be totally stopped in halt mode, and cause all functions stop to save power. The Standby mode is similar to halt mode, except the system clock is still working. However, it is required to execute STB instruction to enter standby mode. Once the AM4F IC is under the standby mode and running for a period of time, the “wakeup” signal, which is generated by internal interrupt or external input change, can lead AM4F IC into the normal operating mode. Under slower system clock, that is standby mode, the power consumption is around 90uA@3V and 180uA@4.5V under the condition of 8MHz (Rosc=390Kohm). Hence, the power-saving program counter function can be applied in this mode. For details, please refer to Alpha’s Application Note number APN-05007.

(8) Each I/O pin can be one of four mask options: **(Mask Option)**

- a) Floating input
- b) IO with input weak pull high **(Register Control)**
- c) Input with weak pull high
- d) Output

(9) There are two ports for large current output: PRA0~3, PRF0~3.

(10) Built-in infrared (IR) carrier output: **(Mask Option)**

There are built-in infrared carrier output ports in the device that can be taken as transmission port in wireless transmission. The built-in IR carrier output can be optioned to high/low carry and be specified frequency with setting its timer value. User can set PRA[1] or PRB[1] as IR carrier pin.

(11) Voice and Timbre encoding method:

- a) 6-bit Alpha ALS-PCM encoding. (Two samples for one word)
- b) 8-bit PCM encoding. (**"B" version only**. One sample for one word, 4 bits are unused for audio data)

(12) MIDI and voice output:

There are eight output channels. User can specify any combination of mixing channels for both DAC1 or DAC2. Each channel can be configured as pure wave play or automatic repeat to easy the implementation of MIDI.

(13) There are three kinds of audio output method. User can select one type of audio output by programming special function registers SPDRV (\$11). **(Register Control)**

- a) One 8 bits PWM output.
- b) Two 10 bits DAC output.
- c) One 10 bits Push-Pull output. **(Only available for AM4FE084B/AM4FE106B/AM4FE127B)**

(14) 16-level volume control **(Register Control)**

There is a 16-level volume control for both PWM and DAC. It is used to control the volume level and to minimize the mixing saturation.

(15) Eight-level current output **(Mask Option)**

There is a mechanism in DAC output in order to increase elasticity of DAC output driving current. User can utilize the current control to change DC working point of DAC output for different bipolar transistor.

(16) Watch Dog Timer **(WDT)**

(17) External Reset: User can set PRA[3] or PRB[3] as reset pin. **(Mask Option)**

(18) There are 4 methods of internal reset:

- a) Power-on reset
- b) Watchdog reset
- c) Low voltage reset
- d) External reset

(19) Number of instruction: 60

3. Memory

3.1 ROM

The ROM memory could be divided into three portions. The first portion 0x0~0xF is addressed for interrupt in normal mode. The second portion 0x10~0x3FF is reserved for test program. The last portion 0x400~0X5FFFF located in the address range that could be accessed by program counter (PC) and others' pointer simultaneously. Address bits[17:16] is accessed by setting PCH value in SFR\$14 to switch banks. That is, each bank has memory space 64K words. This portion could be used to store program and data. Figure 3.1 shows the ROM map.

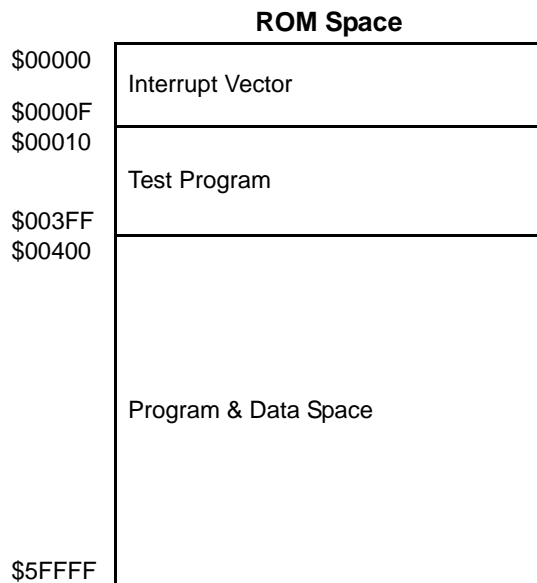

FIGURE 3.1: ROM Map of AM4FExxxx

3.2 SRAM

Each of the two SRAM pages is range form 0x20 to 0xFF, that is 224*4-bit for a page. 0x00~0x1F is left for special function register. Instruction SRB, RRB is limited to apply to SFR and first 32 nibbles SRAM (0x20~0x3F).

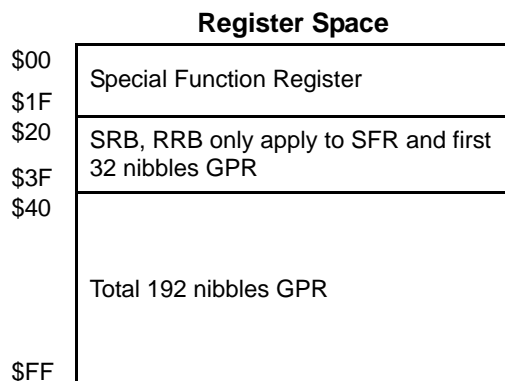

FIGURE 3.2: SRAM Map of AM4F

4. Pin Description

Pad Name	Attr.	Description
PRA0 / PRA2	I/O	Four I/O modes can be optioned for each I/O pin: (1) Floating input mode, (2) IO mode, (3) pull-high input mode, (4) output mode. <i>Or 4 kinds of output current: (1) Normal current, (2) Constant current, (3) Large current, (4) Large and Constant current.</i>
PRA1 / IR	I/O	Four I/O modes can be optioned for each I/O pin: (1) Floating input mode, (2) IO mode, (3) pull-high input mode, (4) output mode. <i>Or 4 kinds of output current: (1) Normal current, (2) Constant current, (3) Large current, (4) Large and Constant current.</i> <i>Or mask_option selected as an IR Carrier Output with programmable 38k / 56kHz.</i>
PRA3 / Reset	I/O	Four I/O modes can be optioned for each I/O pin: (1) Floating input mode, (2) IO mode, (3) pull-high input mode, (4) output mode. <i>Or 4 kinds of output current: (1) Normal current, (2) Constant current, (3) Large current, (4) Large and Constant current.</i> <i>Or Mask_option selected as an external RESET pin with weak pull-high capability.</i>
PRB0 / OSC2	I/O	Four I/O modes can be optioned for each I/O pin: (1) Floating input mode, (2) IO mode, (3) pull-high input mode, (4) output mode. <i>Or crystal output for HM mode.</i>
PRB1 / IR	I/O	Four I/O modes can be optioned for each I/O pin: (1) Floating input mode, (2) IO mode, (3) pull-high input mode, (4) output mode. <i>Or mask_option selected as an IR Carrier Output with programmable 38k / 56kHz.</i>
PRB3 / Reset	I/O	Four I/O modes can be optioned for each I/O pin: (1) Floating input mode, (2) IO mode, (3) pull-high input mode, (4) output mode. <i>Or Mask_option selected as an external RESET pin with weak pull-high capability.</i>
PRB2 PRC0~3 PRD0~3 PRE0~3	I/O	Four I/O modes can be optioned for each I/O pin: (1) Floating input mode, (2) IO mode, (3) pull-high input mode, (4) output mode.

PRF0~3	I/O	Four I/O modes can be optioned for each I/O pin: (1) Floating input mode, (2) IO mode, (3) pull-high input mode, (4) output mode. Or 4 kinds of output current: (1) Normal current, (2) Constant current(Only unavailable for AM4FE031B/AM4FE041B/AM4FE063B), (3) Large current, (4) Large and Constant current(Only unavailable for AM4FE031B/AM4FE041B/AM4FE063B).
OSC1	I	R oscillator input for RM mode, or <i>crystal input</i> for HM mode.
PWM1/DA1	O	PWM1 output, Current Output of Audio 1 or <i>Push-Pull output 1</i> .
PWM2/DA2	O	PWM2 output, Current Output of Audio 2 or <i>Push-Pull output 2</i> .
VDD1~4(or 5)	Power	Positive power supply.
GND1~4(or 5)	Power	Ground Potential.

5. Electrical Characteristics

The Characteristics of AM4FE series are described in the following table. All the data are measured in the room temperature. Different process lot or testing condition may cause variation of data result.

5.1 Absolute Maximum Rating

SYMBOL	RATING	UNIT
V _{SS} ~ V _{DD}	-0.5 ~ +5.5	V
V _{in} (for all input)	V _{SS} -0.3 < V _{in} < V _{DD} +0.3	V
V _{out} (for all output)	GND < V _{out} < V _{DD}	V
T _{op} (Operating)	0 ~ +70	°C
T _{st} (Storage)	-25 ~ +85	°C

5.2 DC Characteristics

SYMBOL	PARAMETER	V _{DD}	MIN.	TYP.	MAX.	UNIT	CONDITION
V _{DD}	Operating voltage		2.4	3	5.5	V	8 MHz
I _{ht}	Supply current	Halt	3		1	uA	Halt (Sleep) mode
			4.5		2		
I _{sb}	Supply current	Standby	3	90		uA	Standby mode 8MHz, RM
			4.5	180			
I _{op}	Supply current	Operating	3	3		mA	8MHz, RM, I/O No Loading
			4.5	6			
I _{il}	Input current (Internal weak pull-high)	Option 0	3	-3.8		uA	V _{il} =0v
			4.5	-10			
		Option 1	3	-7.5			
			4.5	-20			
I _{oh}	Output high current	3	-6		mA	V _{oh} =2.70v	
		4.5	-15			V _{oh} =3.75v	
I _{ol}	Output low current (disable large current / disable constant current)	3	13			V _{ol} =0.65v	
		4.5	26			V _{ol} =1.30v	
I _{ol}	Output low current (enable large current / disable constant current)	3	26			V _{ol} =1.30v	
		4.5	50			V _{ol} =2.50v	
I _{ol}	Output low current (disable large current / enable constant current)	3	11			V _{ol} =0.55v	
		4.5	12			V _{ol} =0.60v	
I _{ol}	Output low current (enable large current / enable constant current)	3	21			V _{ol} =1.05v	
		4.5	22			V _{ol} =1.10v	
I _{PWM}	PWM output current	3	16		mA	Load=8 ohms	
		4.5	23				
I _{push-pull}	Push-pull maximum power	3	41		mA	Load=8 ohms	
		4.5	83				
C _{out}	DA1 and DA2 output current	3	0.96 ~ 4.06		mA	8MHz, RM (Full scale)	
		4.5	1.06 ~ 4.34				
dF/F	Frequency stability	3	-3		3	%	F _{osc} (3v) - F _{osc} (2.4v) F _{osc} (3v)
dF/F	Fosc lot variation	3	-8		8	%	8MHz

5.3 Typical Rosc and VDD for RM Mode Oscillator of AM4FExxxx

VDD	Oscillator Frequency				
	Rosc=430K	Rosc=390K	Rosc=360K	Rosc=270K	Rosc=180K
1.8 V	6.63 MHz	7.32 MHz	7.91 MHz	11.48 MHz	14.70 MHz
1.9 V	6.68 MHz	7.48 MHz	8.06 MHz	11.82 MHz	15.12 MHz
2.0 V	6.78 MHz	7.56 MHz	8.10 MHz	11.93 MHz	15.55 MHz
2.5 V	6.98 MHz	7.79 MHz	8.38 MHz	12.42 MHz	16.49 MHz
3.0 V	7.01 MHz	7.87 MHz	8.53 MHz	12.63 MHz	16.67 MHz
3.5 V	7.03 MHz	7.91 MHz	8.55 MHz	12.69 MHz	16.83 MHz
4.0 V	7.03 MHz	7.92 MHz	8.55 MHz	12.72 MHz	16.83 MHz
4.5 V	7.05 MHz	7.94 MHz	8.55 MHz	12.78 MHz	16.91 MHz
5.0 V	7.07 MHz	7.94 MHz	8.55 MHz	12.78 MHz	16.91 MHz
5.5 V	7.07 MHz	7.95 MHz	8.59 MHz	12.81 MHz	16.90 MHz
6.0 V	7.09 MHz	7.99 MHz	8.66 MHz	12.81 MHz	16.92 MHz

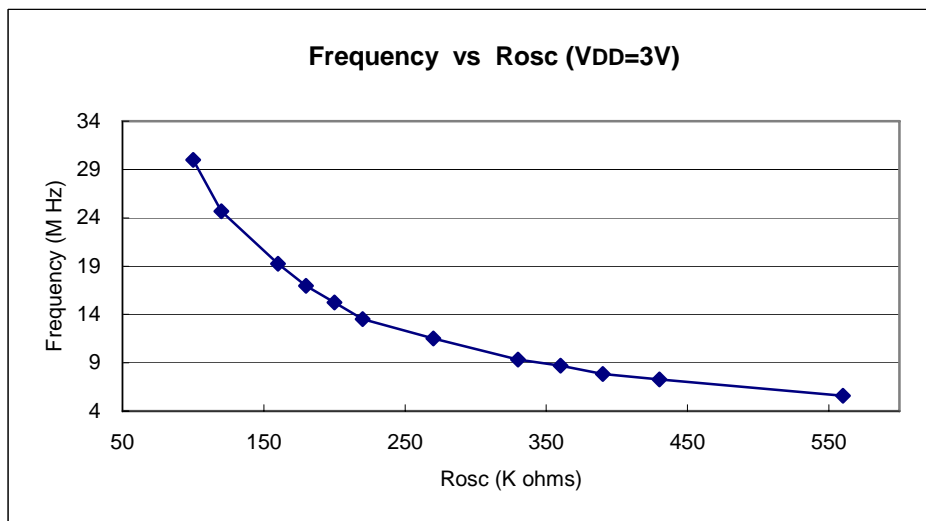
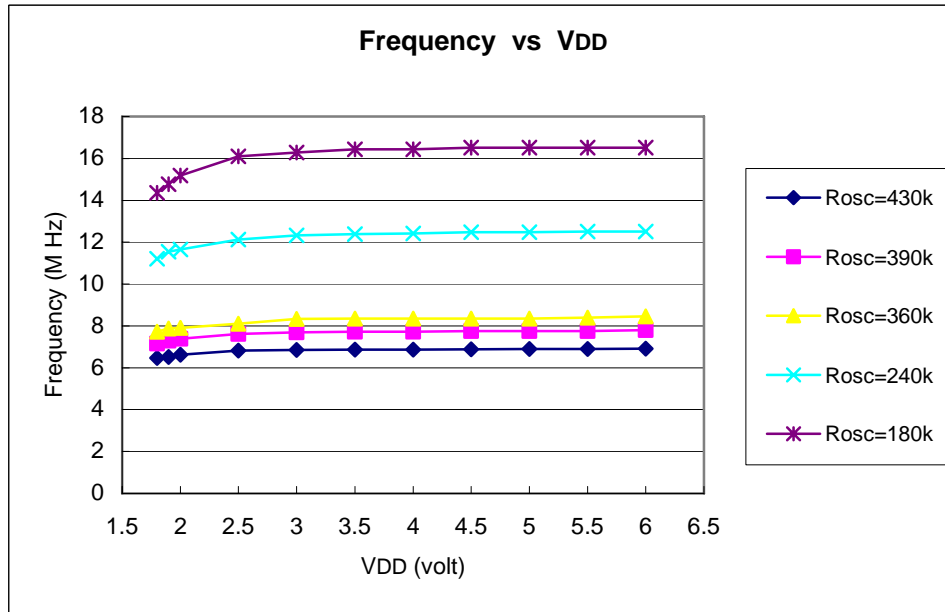

5.4 Typical DAC Output Current of AM4FExxxx (Full Scale for each DAC)

Option	1	2	3	4	5	6	7	8
DAC Current (V _{DD} =3V)	0.88 mA	1.34 mA	1.76 mA	2.18 mA	2.62 mA	3.06 mA	3.48 mA	3.84 mA
DAC Current (V _{DD} =4.5V)	0.98 mA	1.48 mA	1.96 mA	2.38 mA	2.88 mA	3.36 mA	3.82 mA	4.2 mA

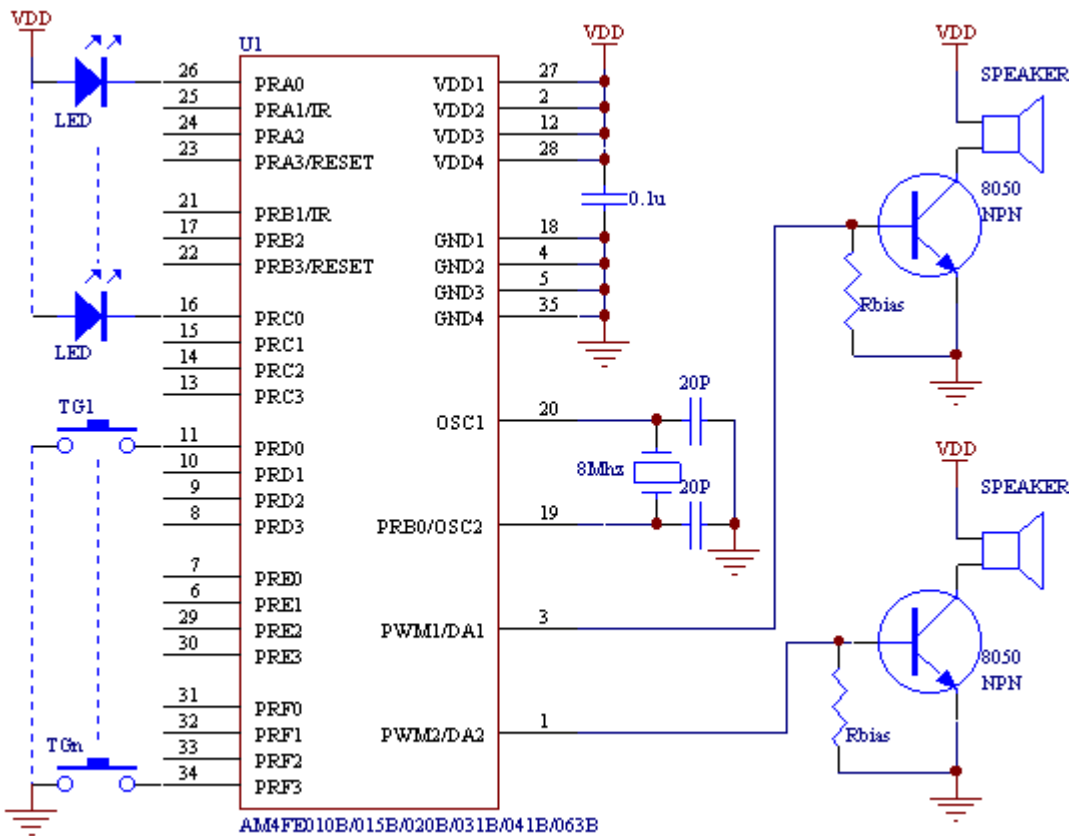
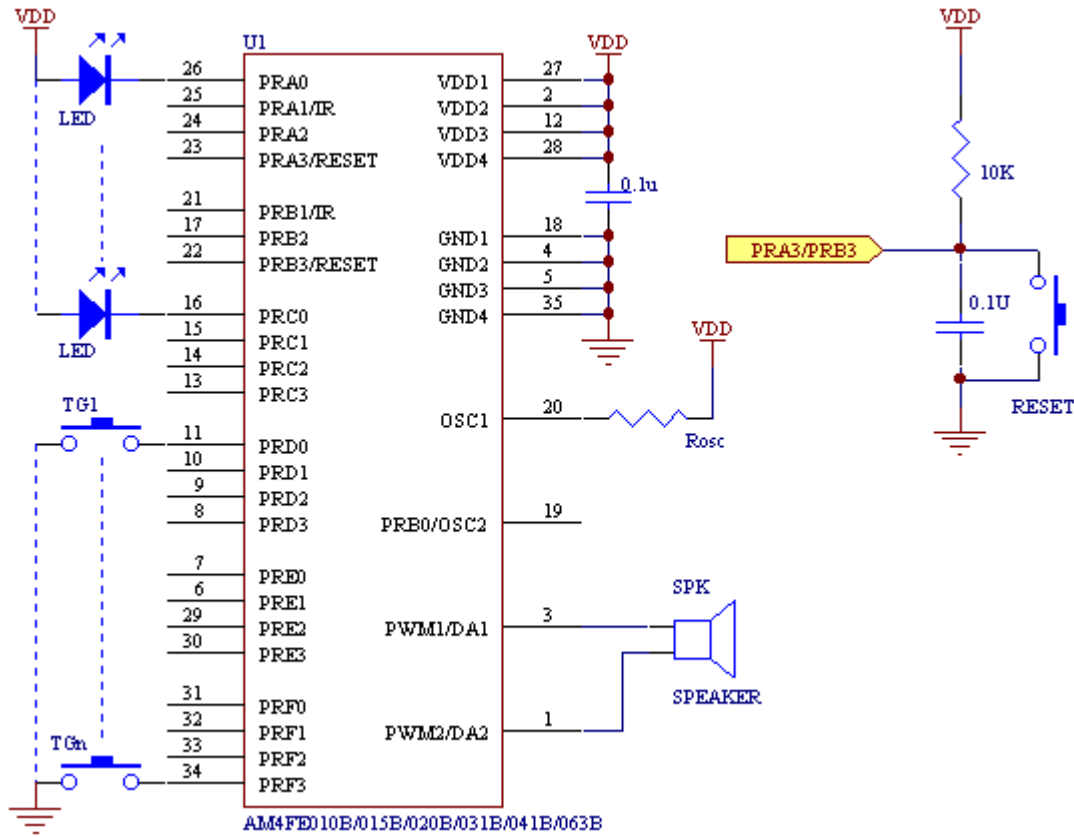
6. Application Circuit (AM4FE010B/015B/020B/031B/041B/063B)

Rbias = 510Ω ~ 1.2KΩ.

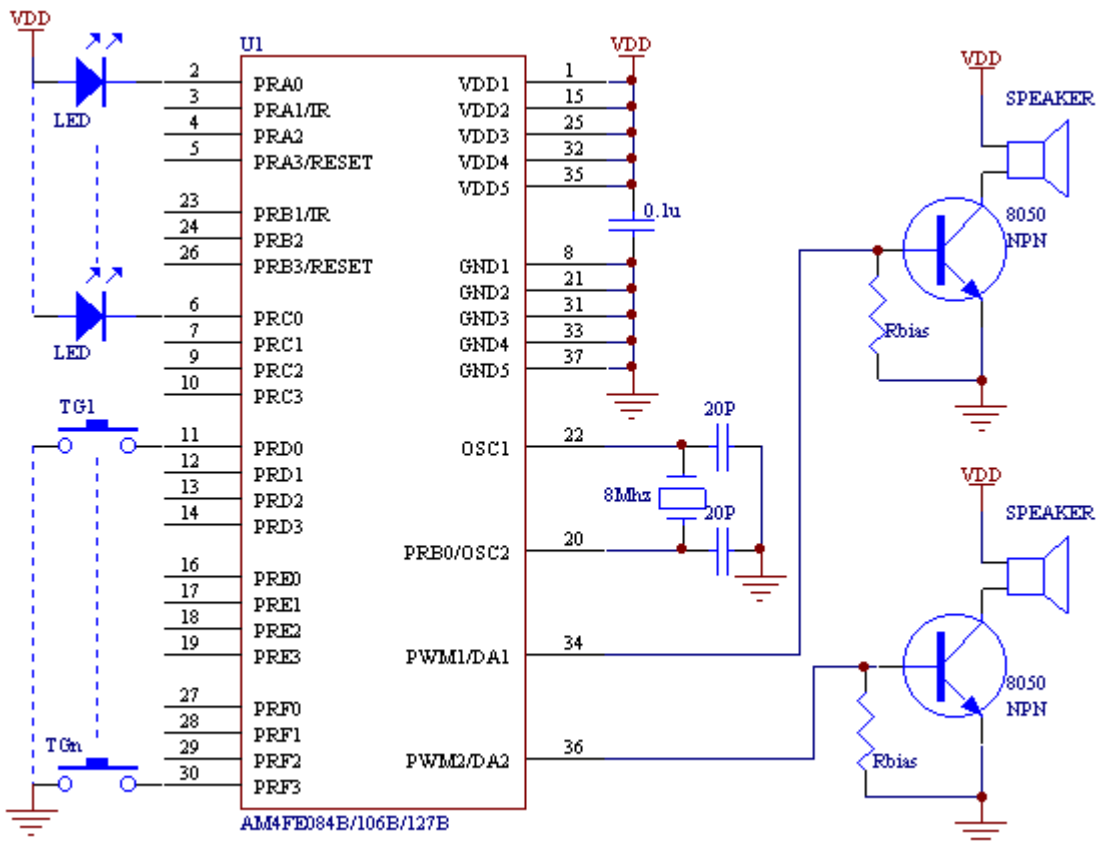
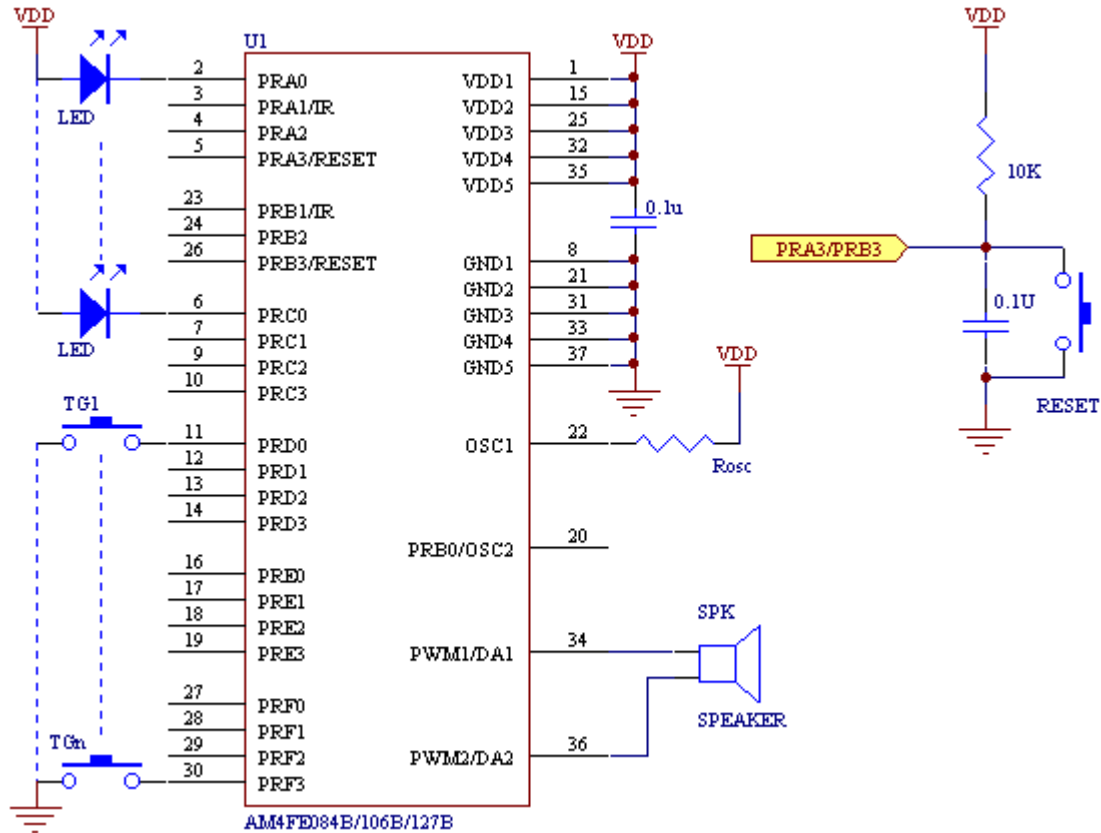
7. Application Circuit (AM4FE084B/106B/127B)

Rbias = 510Ω ~ 1.2KΩ

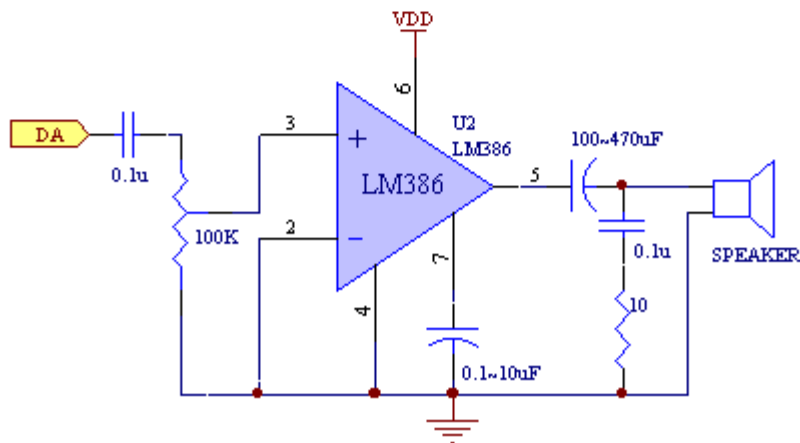
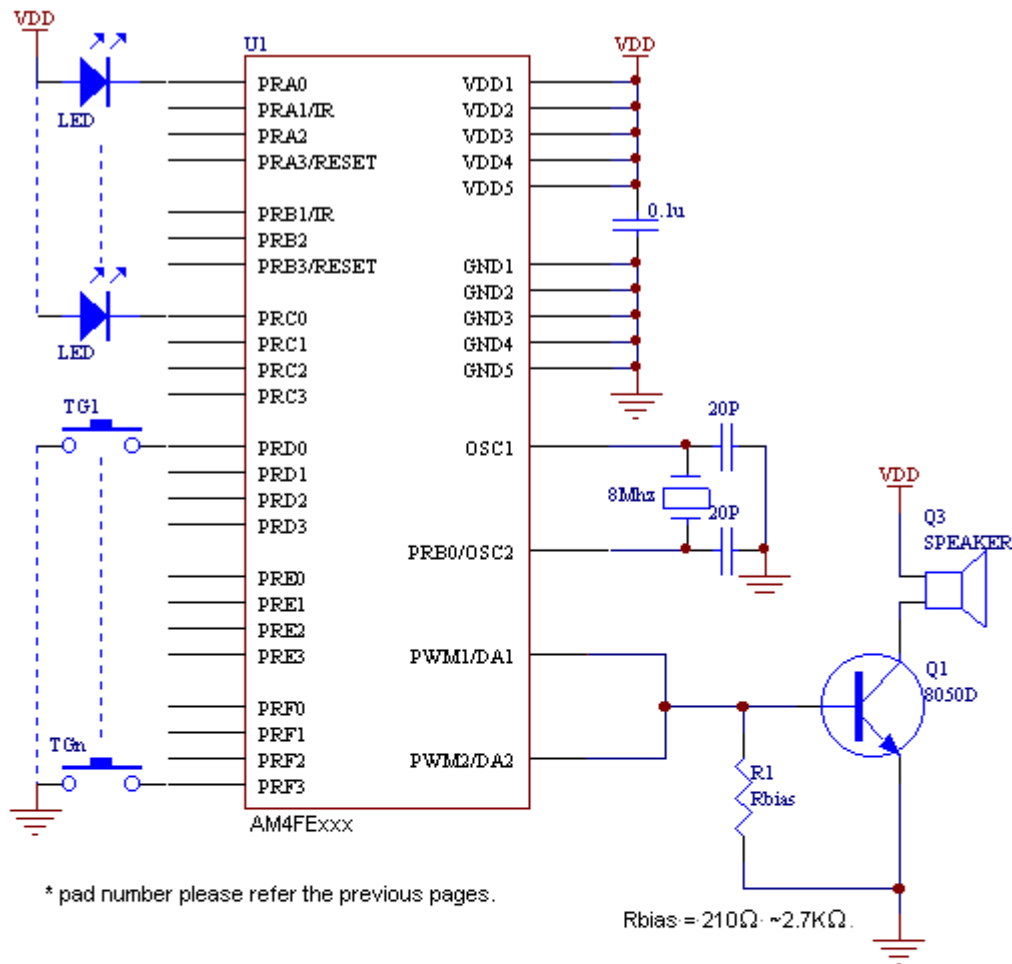

8. Bonding Diagram

8.1 AM4FE010B/AM4FE015B/AM4FE020B/AM4FE031B/AM4FE041B/AM4FE063B

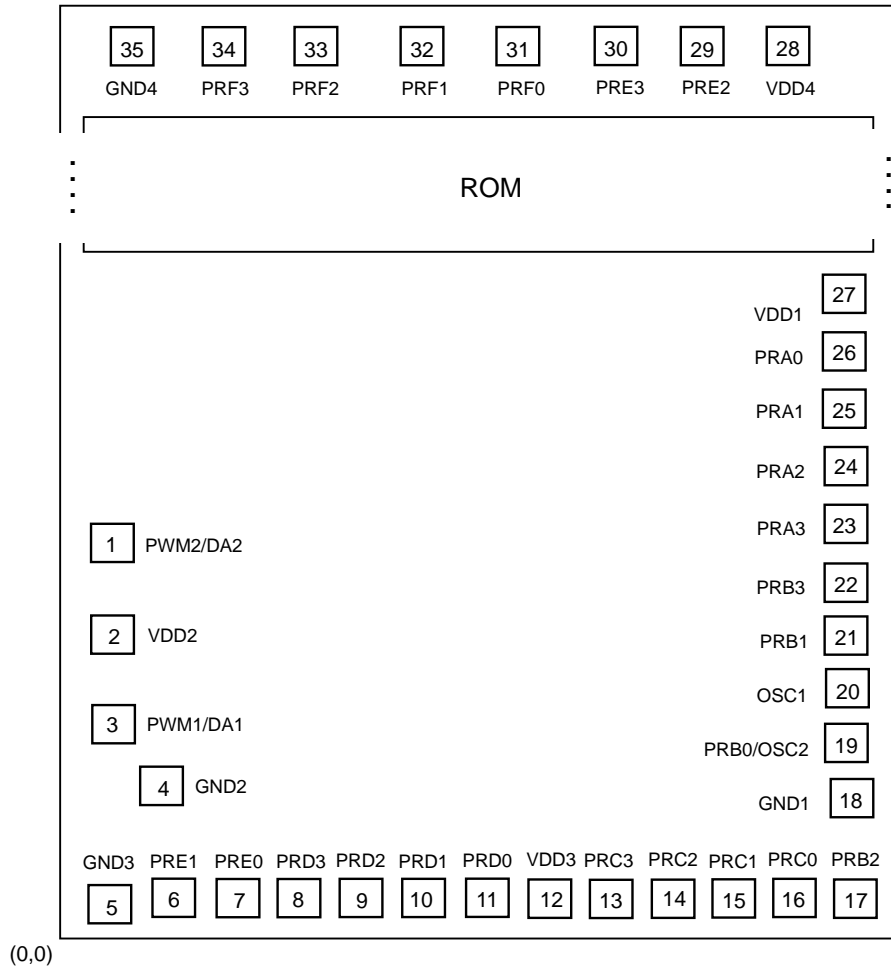

Note: The IC substrate must be connected to GND.

8.2 AM4FE084B/AM4FE106B/AM4FE127B

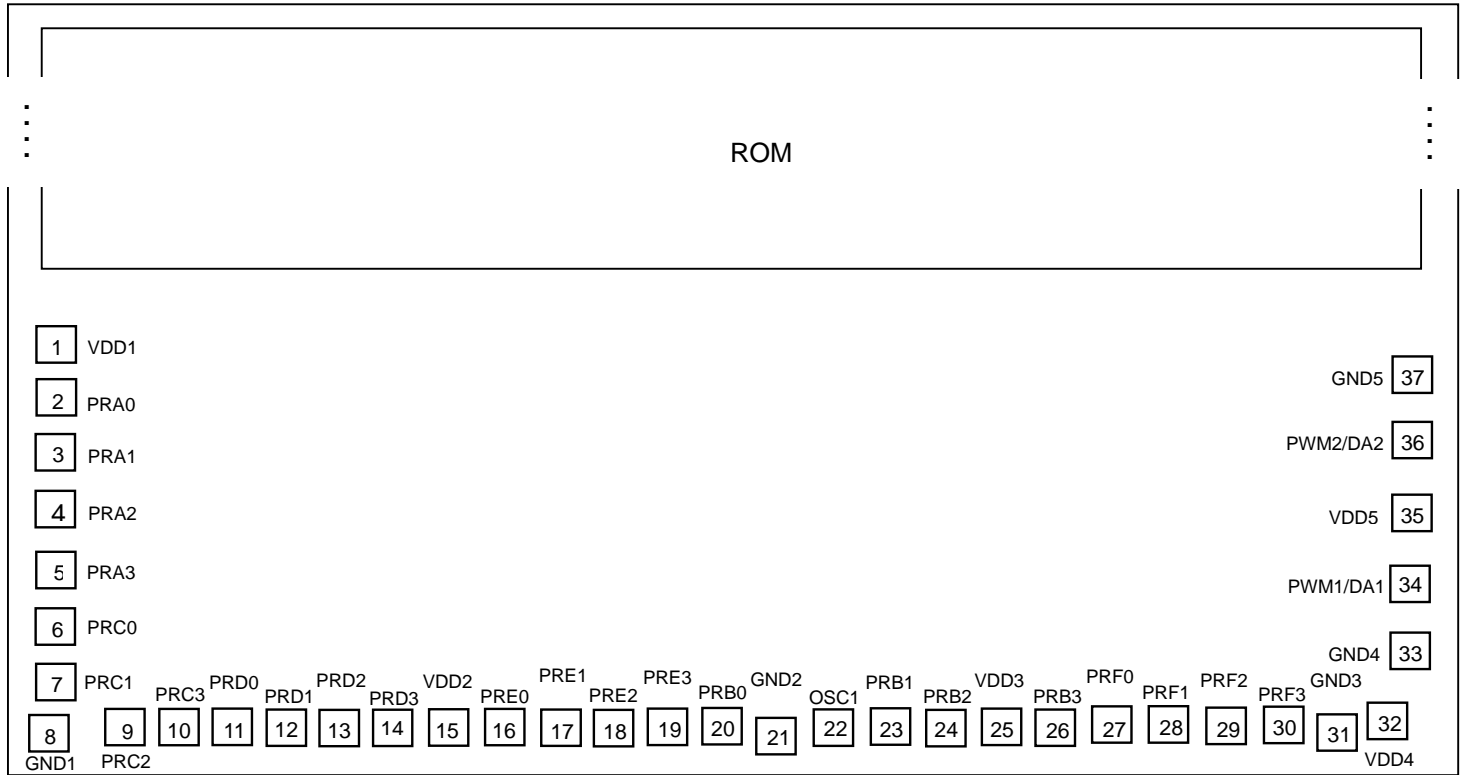

(0,0)

Note: The IC substrate must be connected to GND.